

More info at:
WWW.TRAKRACER.COM



or follow us at:



@TRAKRACER

TR120S - MANUAL VERSION 1A

TR120S SIMULATOR

Assembly Guide



IMPORTANT: Different regions may have different models. Please ensure the part numbers on the following pages match those on your product packaging.

01
SYMBOL LEGEND 01

02
PART LIST 02

03
ASSEMBLY NOTES
TR120S 04

04
ASSEMBLY INSTRUCTIONS
TR120S 07
PEDAL OPTIONS 20
TR80-PBPL2 21
TR80-PBAL2 29
TR80-HYPL2 39

SYMBOL LEGEND



IMPORTANT: Since there are different versions of each product based on your region, please make sure you are using the correct set of instructions. The part numbers on the following page should match the numbers on your product packaging.



IMPORTANT: Due to the nature of cut aluminum profiles, some metal shavings may remain despite our thorough QA cleaning process. We recommend opening boxes and packaging on a hard surface.



NOTE: Some screws and washers may be pre-installed. These are included in the parts list and will need to be loosened and reattached according to the instructions.



Recommended:
Two people for the task



Safety glasses required



Tighten the hardware



Attention/Priority needed



Keep the hardware loose
for adjustments



Reserve for the next step



Make the necessary adjustments









Mirrored components
(same on both sides)

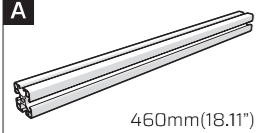
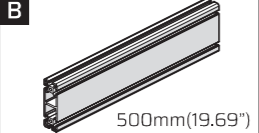

Break the tab off the corner bracket

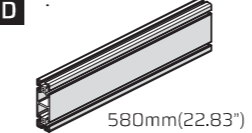
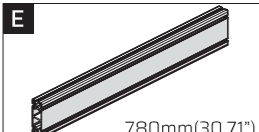
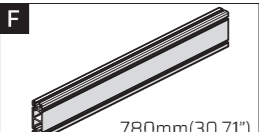
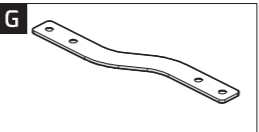
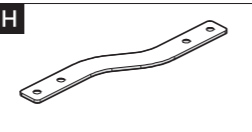
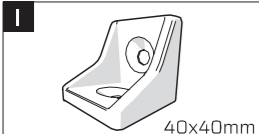
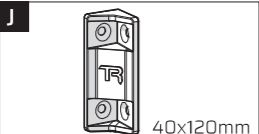
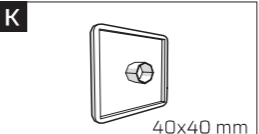
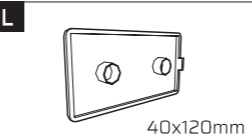
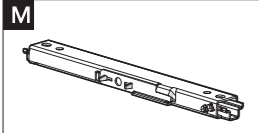
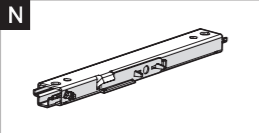
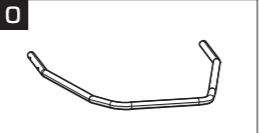
PART LIST

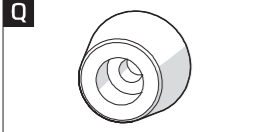
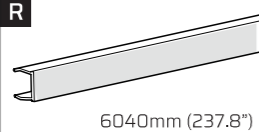
COMPONENTS

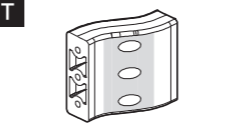
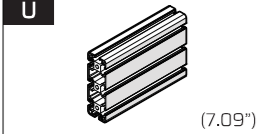
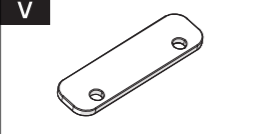
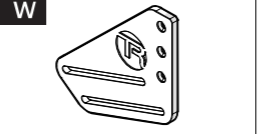
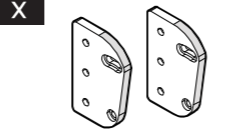
A  460mm(18.11") Aluminum Profile AP-4040-460 X2	B  500mm(19.69") Aluminum Profile AP-40120-500 X2	C  580mm(22.83") Chassis Rear End AP-40120-580-1 X1	D  580mm(22.83") Aluminum Profile AP-40120-580 X1
E  780mm(30.71") Aluminum Profile (Threaded) AP-40120-780-B X2	F  780mm(30.71") Aluminum Profile AP-40120-780-A X2	G  Middle Connector Plate MCP-01 X1	H  Middle Connector Plate MCP-02 X1
I  40x40mm Corner Bracket CB-40 X8	J  40x120mm Corner Bracket CB-120 X6	K  40x40 mm End Cap EC-40 X4	L  40x120mm End Cap EC-120 X2
M  Seat Slider Right SSR-R X1	N  Seat Slider Left SSL-L X1	O  Seat Slider Lever SSL-01 X1	P  Front Logo Plate FLP X1
Q  Rubber Feet FR-01 X6	R  6040mm (237.8") Red Profile Strip PS-6040 X1	S  Cable Management Clip CMC X10	T  Middle Connector Par MCP-03 X2
U  (7.09") Aluminum Profile TR-40120-180 X2	V  Mounting Plate PM X4	W  Outer Installation Plate PIO X2	X  Middle Mounting Plate PMM X1

PART LIST

ACCESSORIES

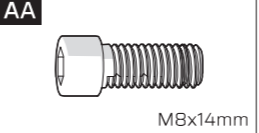
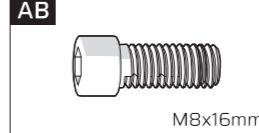
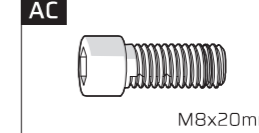
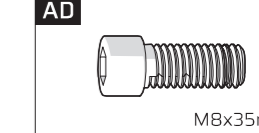
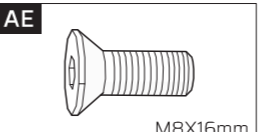
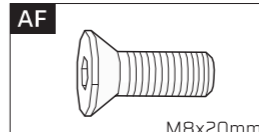
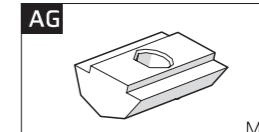
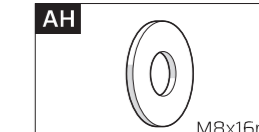
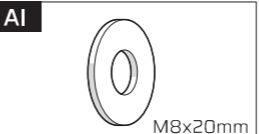
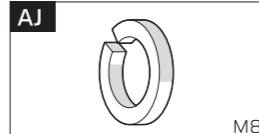
AA  M8x14mm Hex Screw SH-M8-14 X5	AB  M8x16mm Hex Screw SH-M8-16 X5	AC  M8x20mm Hex Screw SH-M8-20 X7	AD  M8x35mm Hex Screw SH-M8-35 X10
AE  M8x16mm Screw (Flat) SF-M8-16 X42	AF  M8x20mm Screw (Flat) SF-M8-20 X14	AG  M8 Ball Bearing Nut NS-M8 X52	AH  M8x16mm Washer (Flat) WF-M8-16 X4
AI  M8x20mm Washer (Flat) WF-M8-20 X6	AJ  M8 Washer (Lock) WL-M8 X9		

INCLUDED TOOLS

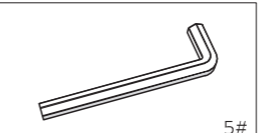
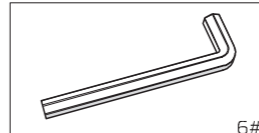
 5# 5mm Hex Key 5# X1	 6# 6mm Hex Key 6# X1
--	--

NOTE: Extra hardware may be included as spare parts.

ASSEMBLY NOTES

TR80S

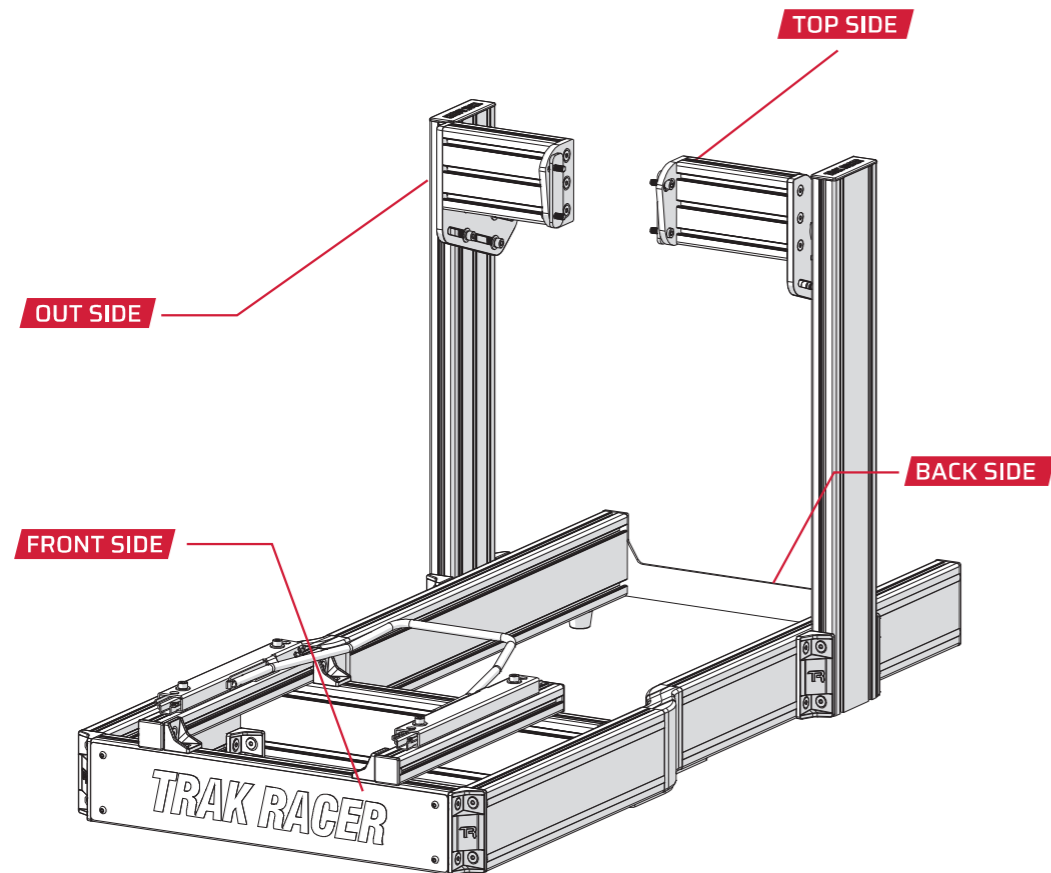

INSTALLATION ORDER FOR SCREWS WASHERS

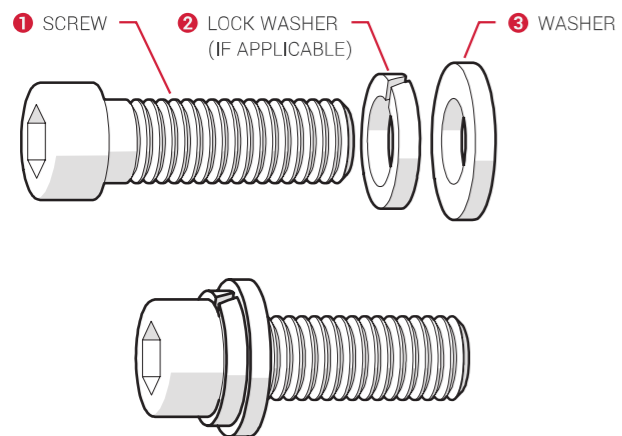

HOW TO MEASURE SCREWS

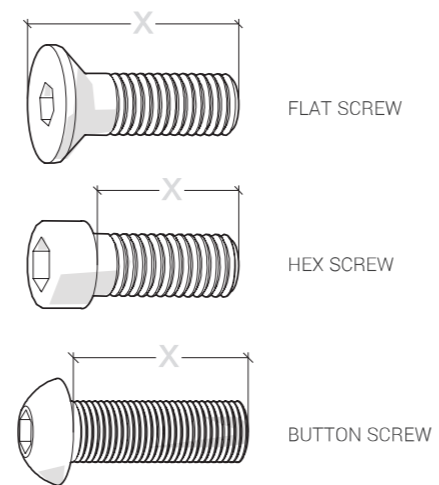

ASSEMBLY NOTES

BC-40-BLK & CB-40

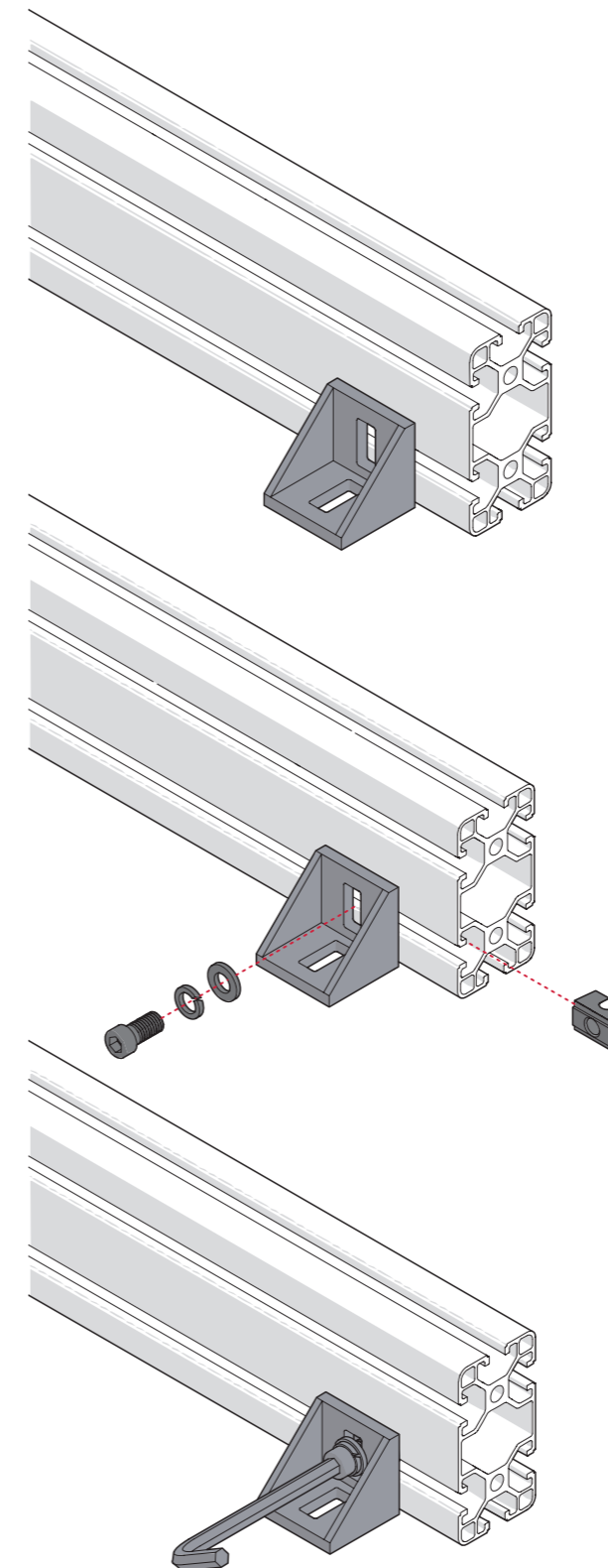

These brackets come with guide tabs on the rear. These tabs help align the brackets to the profile when fitted in the same orientation as the profile. When used in the alternate orientation, these tabs are designed to snap off for a flush mount against the profile.

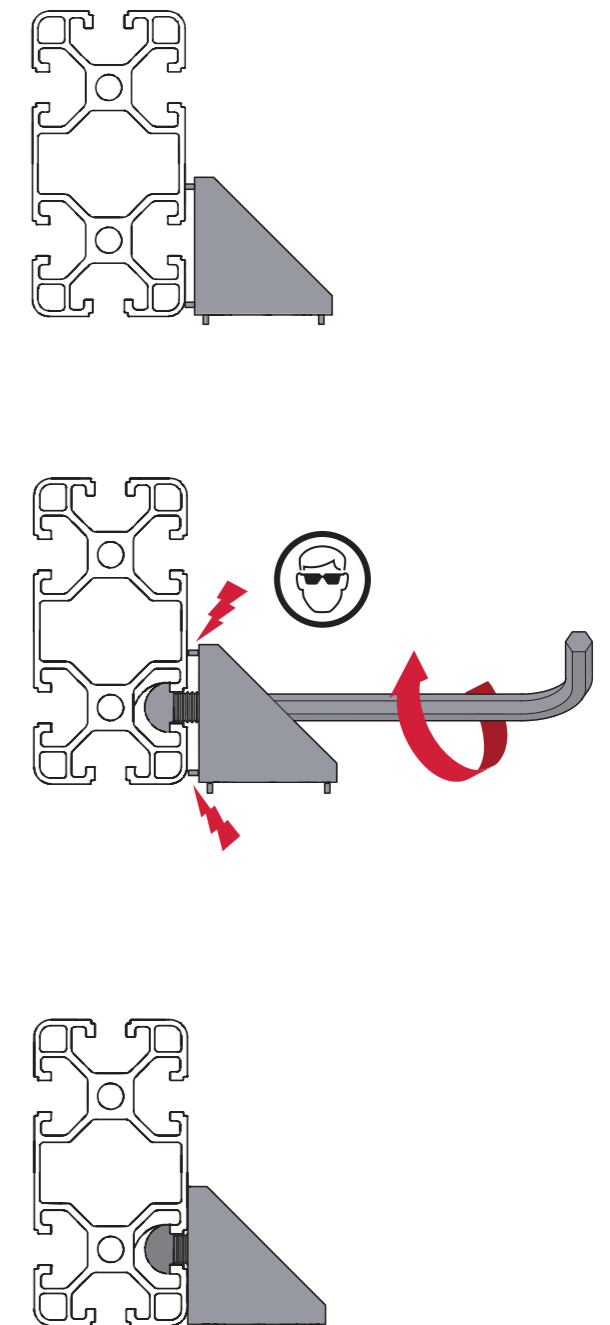

ASSEMBLY NOTES

NS-M8 & NS-M6

Slide T-Nuts into the ends of the profiles. Some must be added early, so follow the 74.34 mm Y: 790.89 mm steps in this manual carefully.

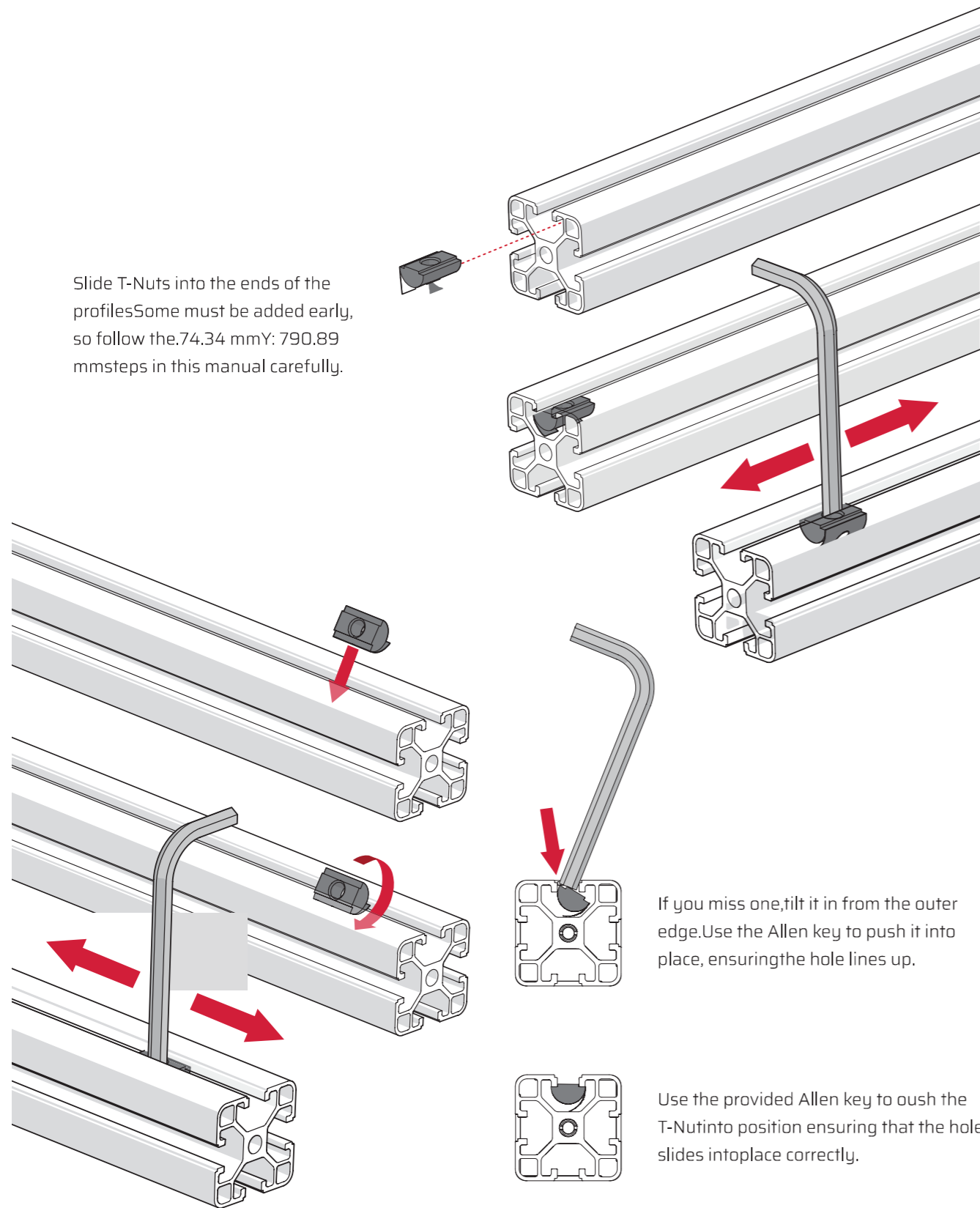

ASSEMBLY INSTRUCTIONS

TR120S

01

SUPPLIED			
A X2	I X4	AE X4	AG X4
AP-4040-460	CB-40	SF-M8-16	NS-M8

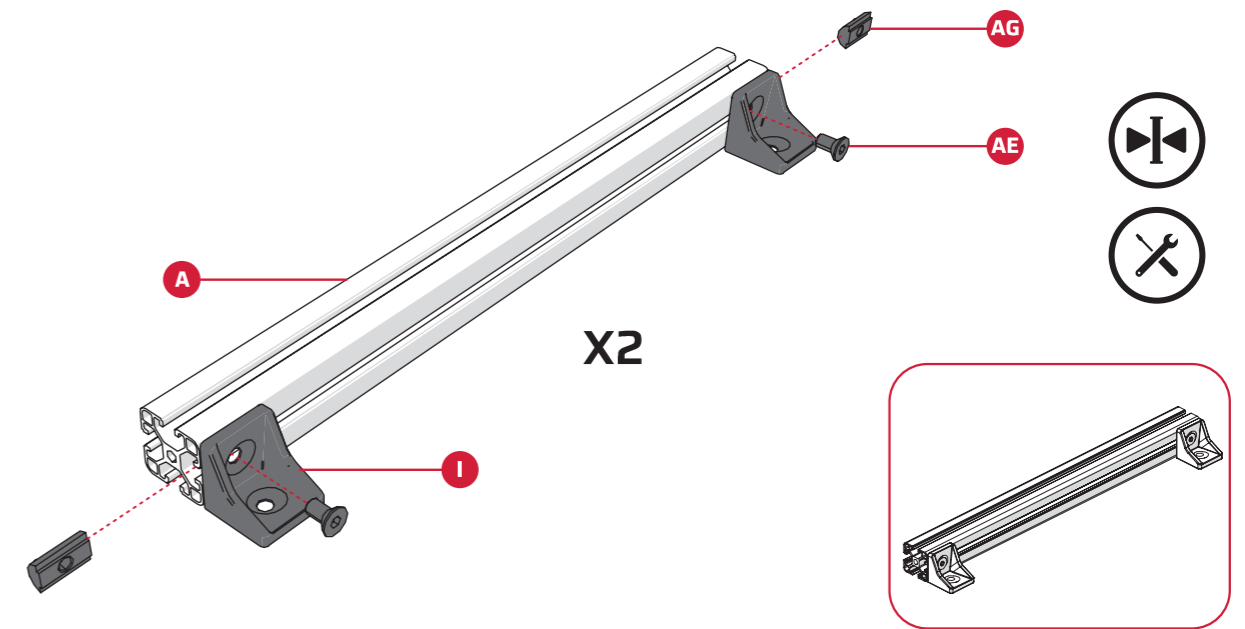

02

SUPPLIED			
C X1	D X1	AG X4	AE X4
TRAK RACER	AP-40120-580-1	NS-M8	SF-M8-16

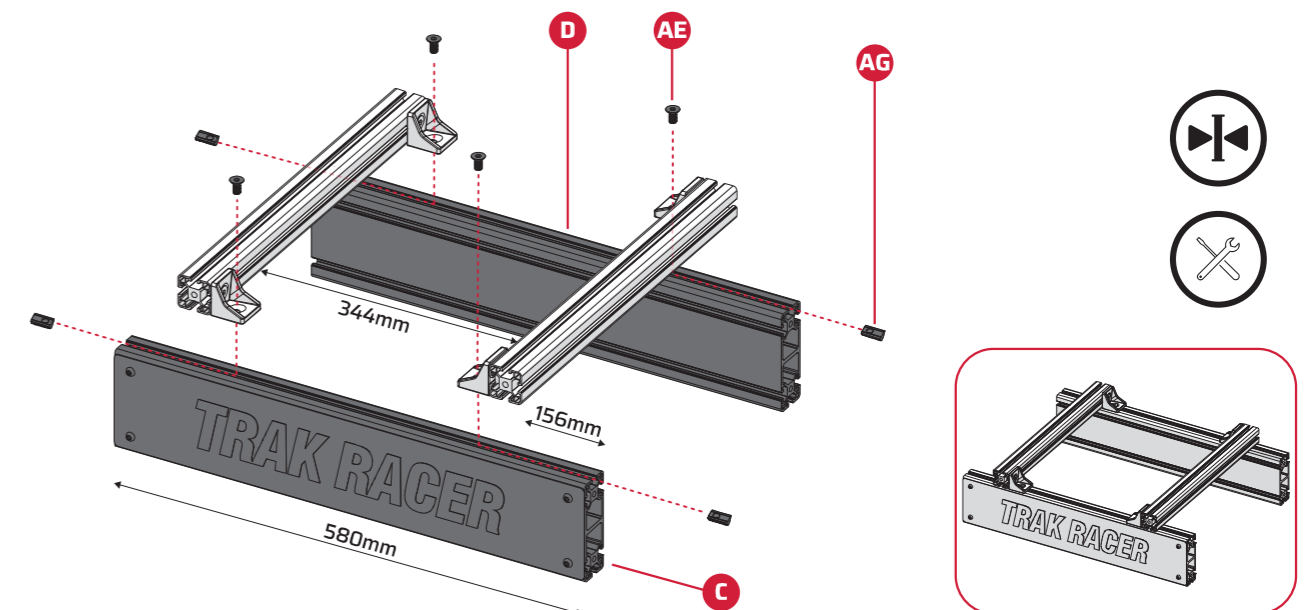

ASSEMBLY INSTRUCTIONS

TR120S

03

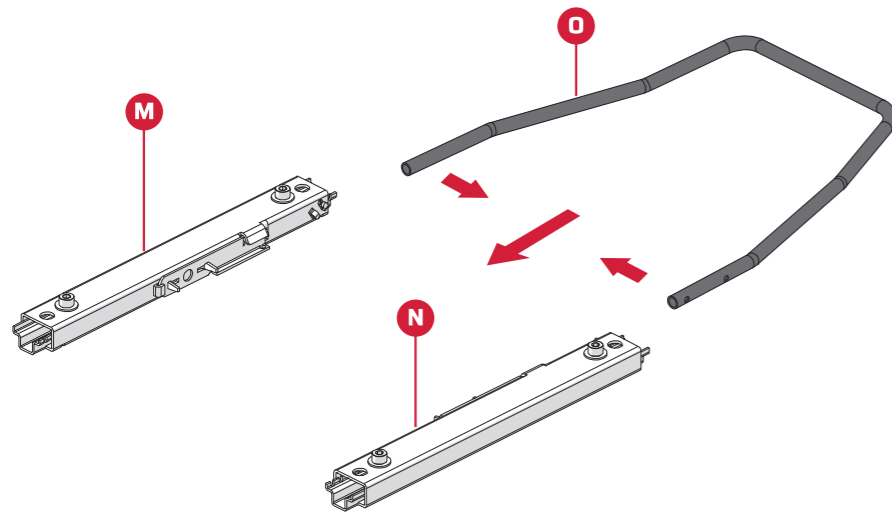
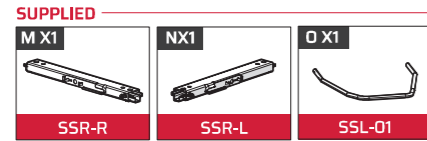

Fit tabs into holes of one side of the lever then squeeze lever and repeat for opposite side.

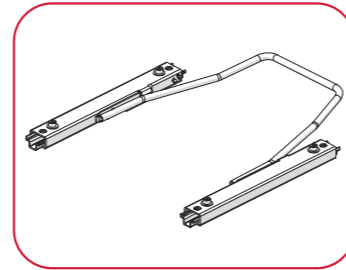

04

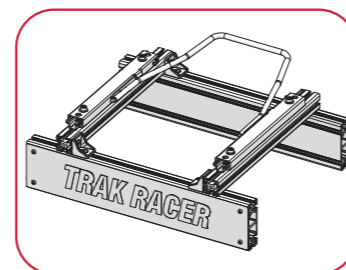
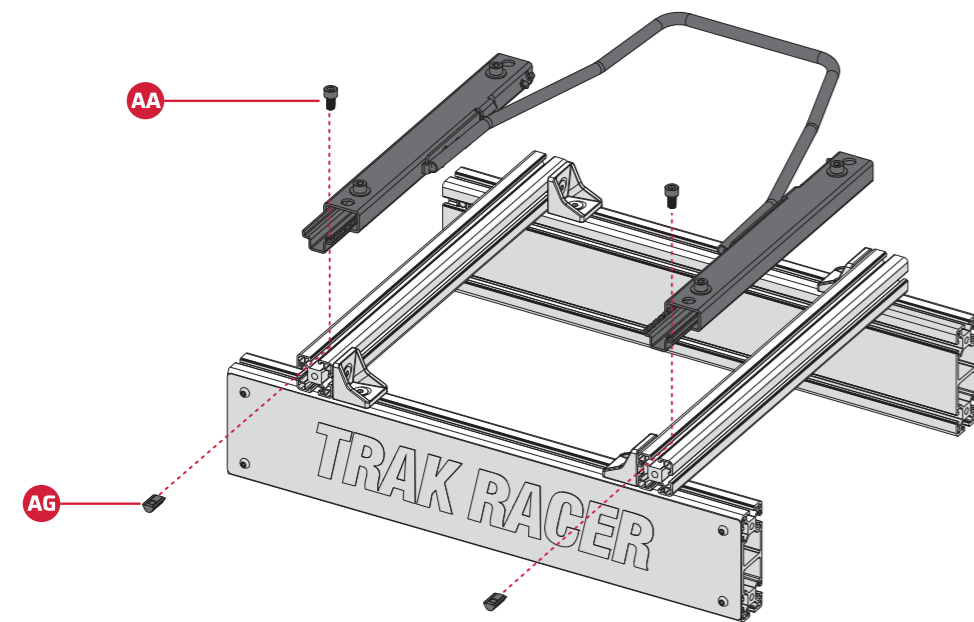
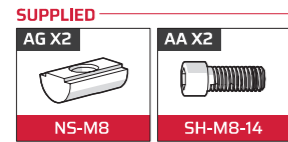

08

ASSEMBLY INSTRUCTIONS

TR120S

05

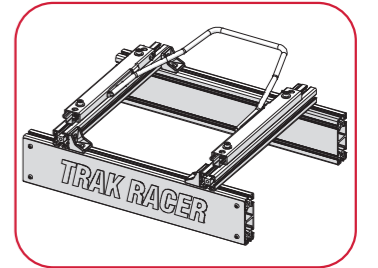
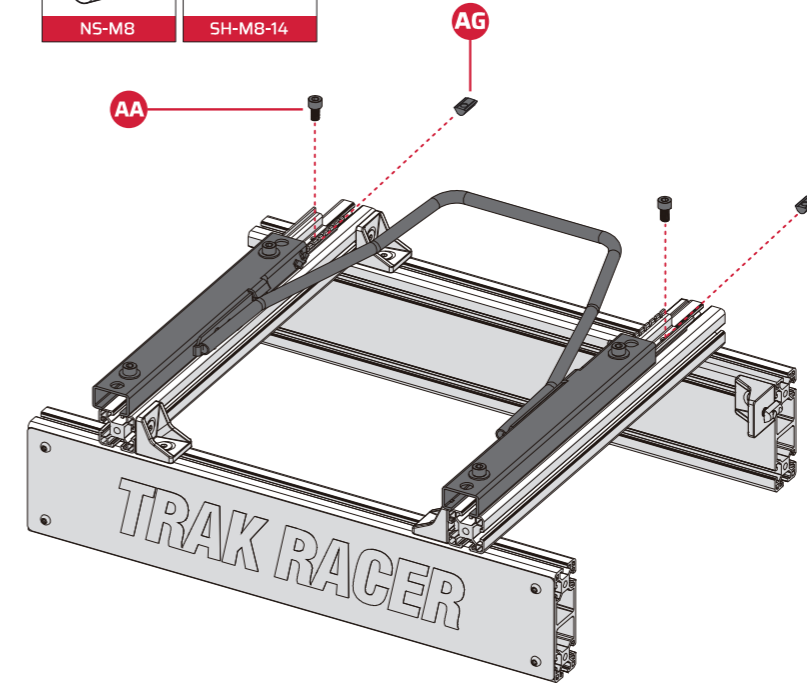
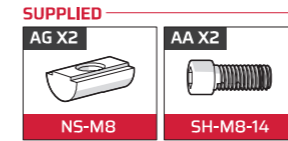

06

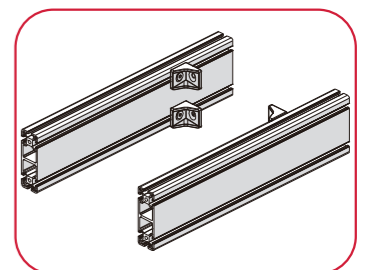
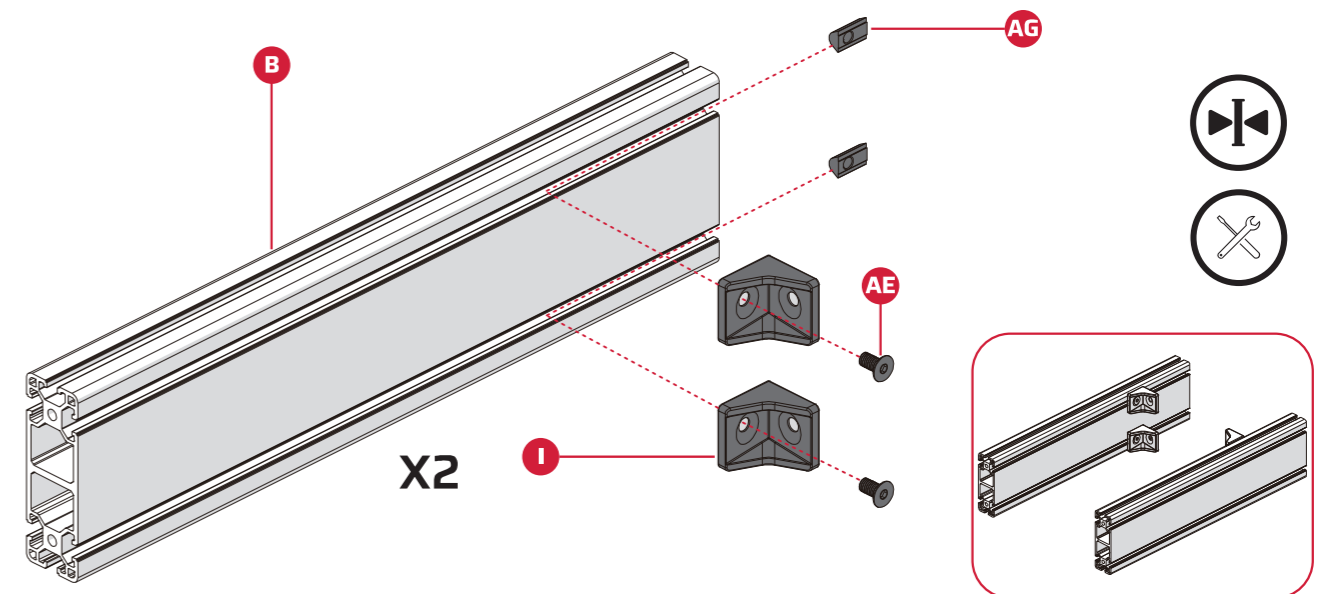
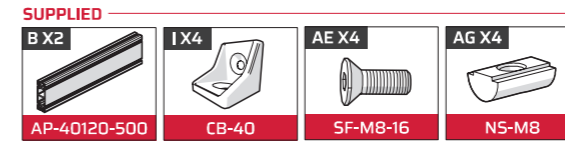

09

ASSEMBLY INSTRUCTIONS

TR120S

07

SUPPLIED			
Q X2	AGX4	AC X4	AH X4
FR-01	NS-M8	SH-M8-20	WF-M8-16

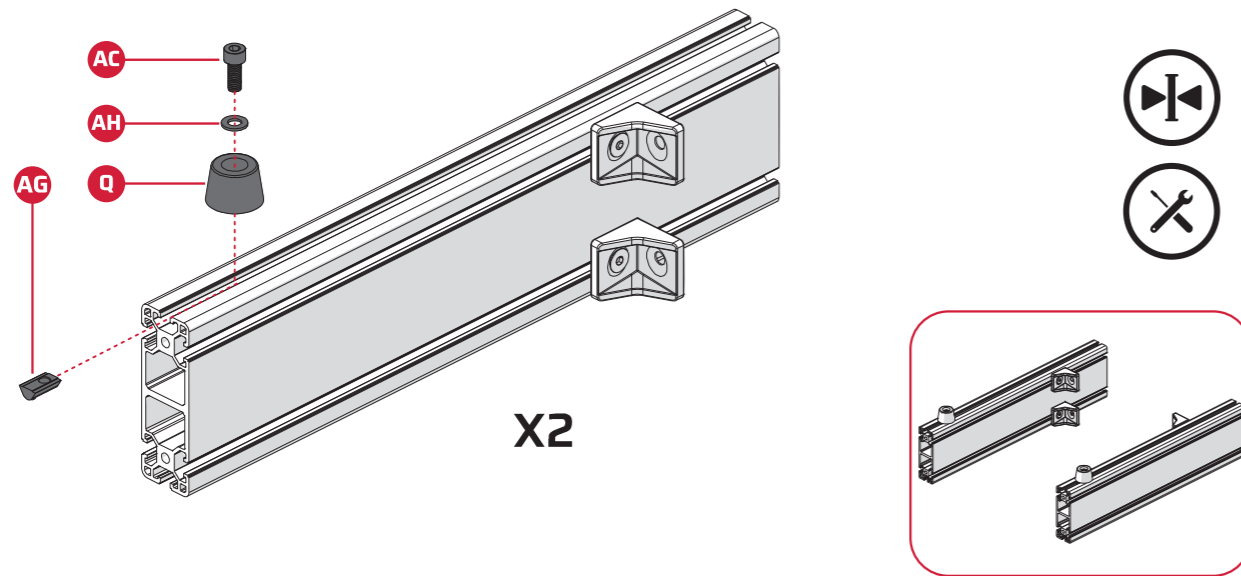

08

SUPPLIED				
E X2	Q X2	AGX4	AC X4	AH X4
AP-40120-780-B	FR-01	NS-M8	SH-M8-20	WF-M8-16

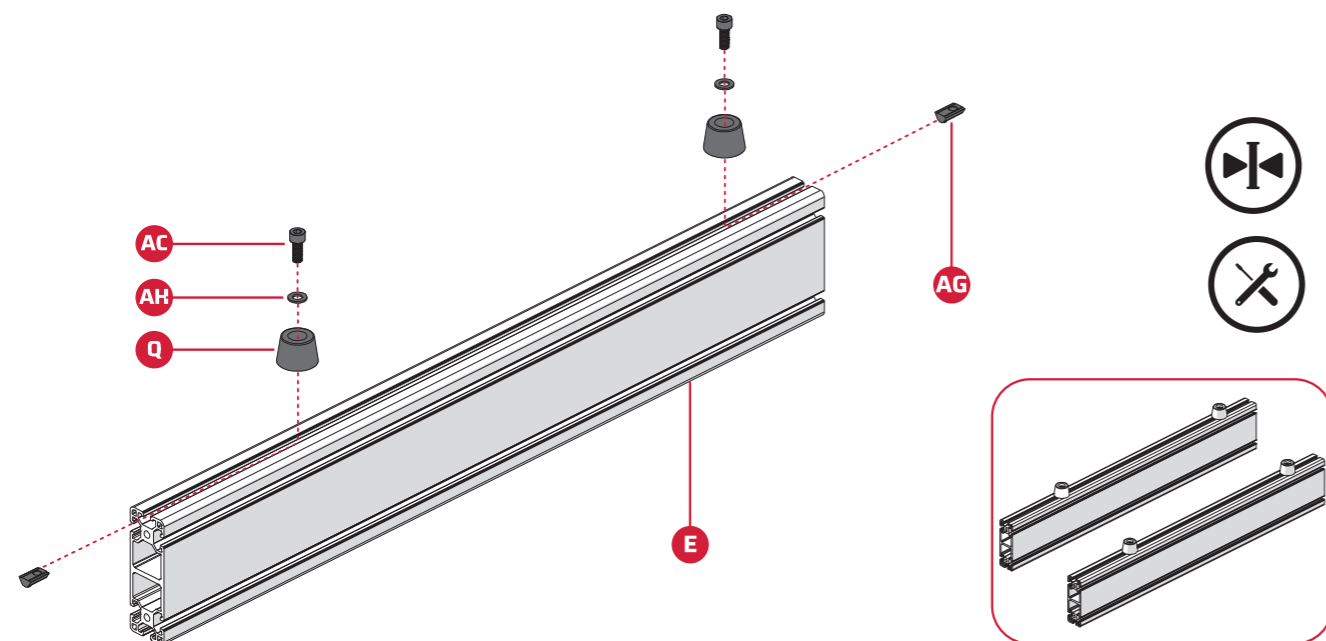

ASSEMBLY INSTRUCTIONS

TR120S

09

SUPPLIED		
G X1	AE X4	AG X4
MCP-01	SF-M8-16	NS-M8

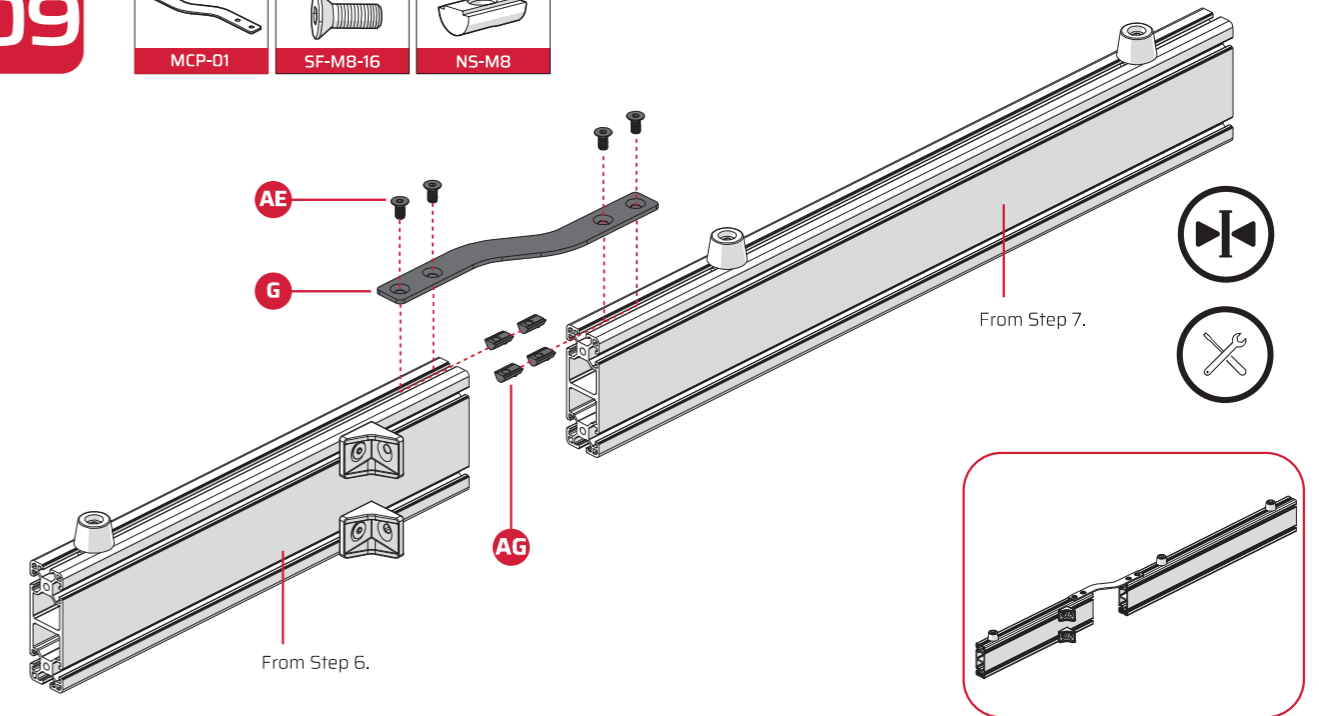

10

SUPPLIED		
H X1	AE X4	AG X4
MCP-02	SF-M8-16	NS-M8

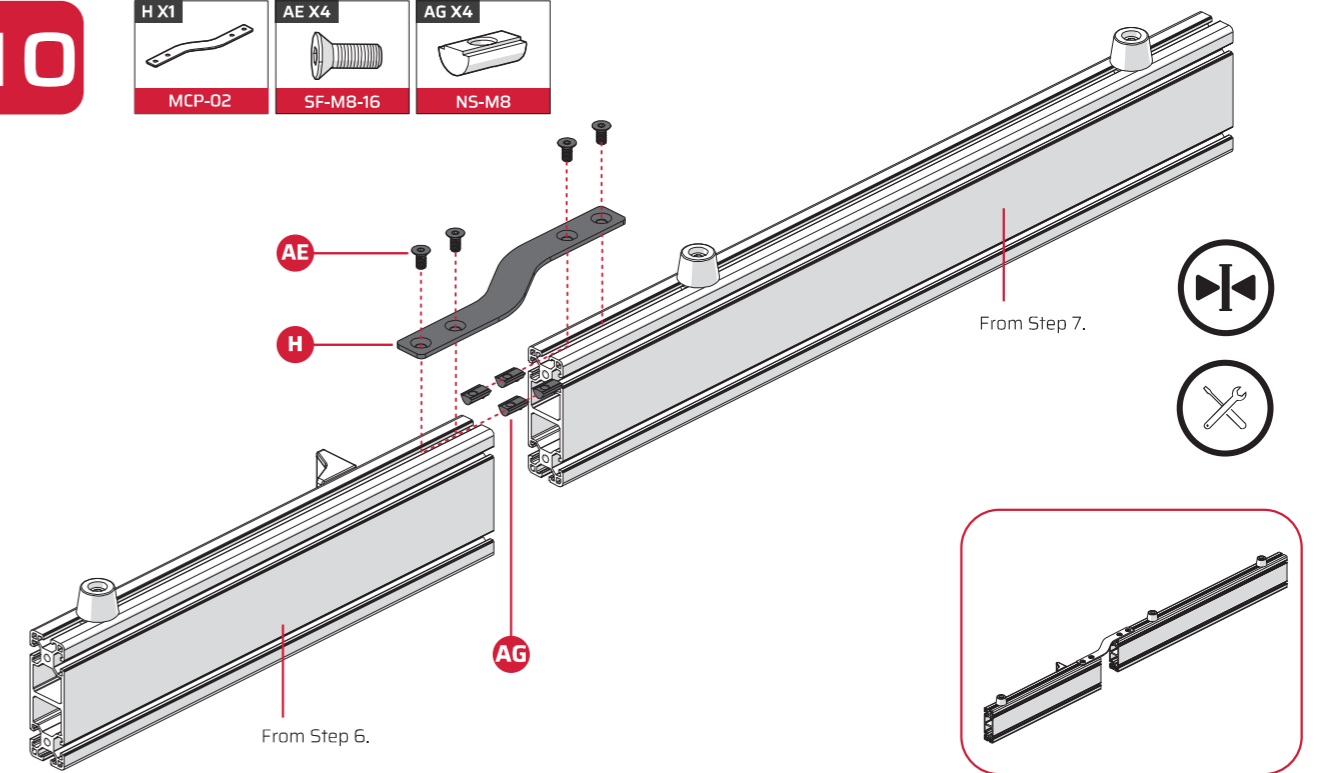

ASSEMBLY INSTRUCTIONS

TR120S

14

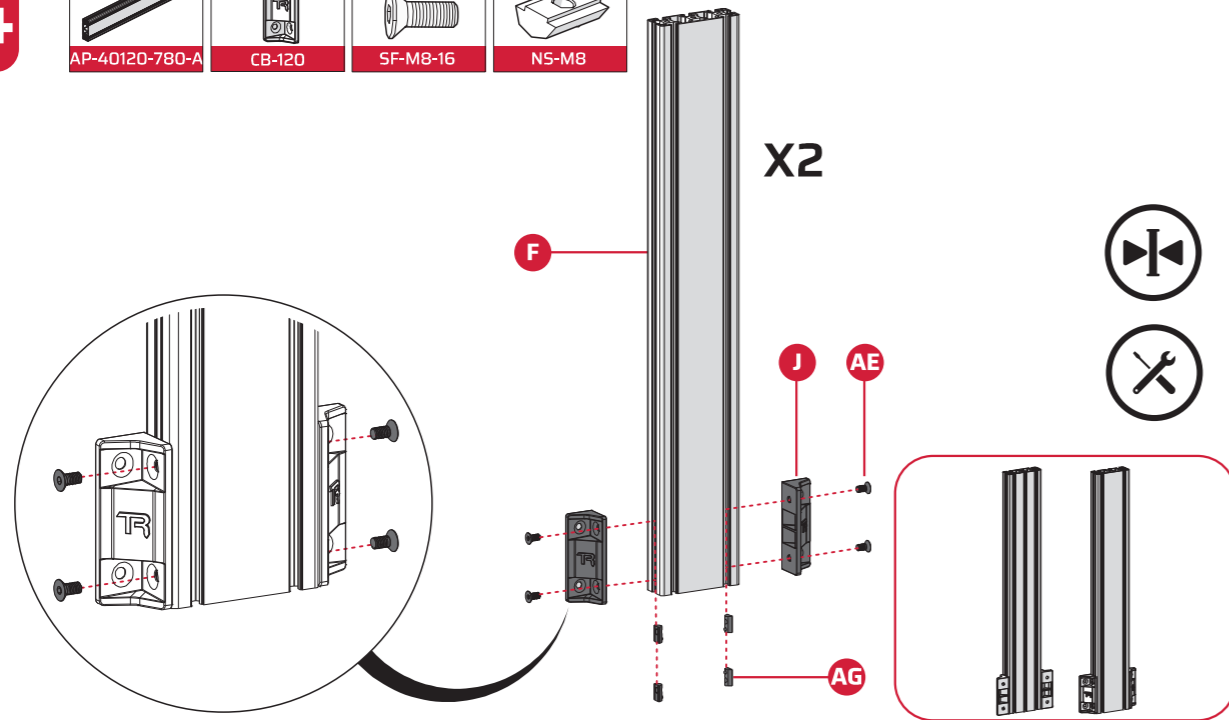
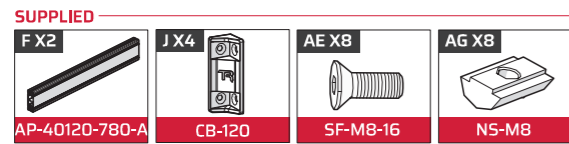

ASSEMBLY INSTRUCTIONS

TR120S

16

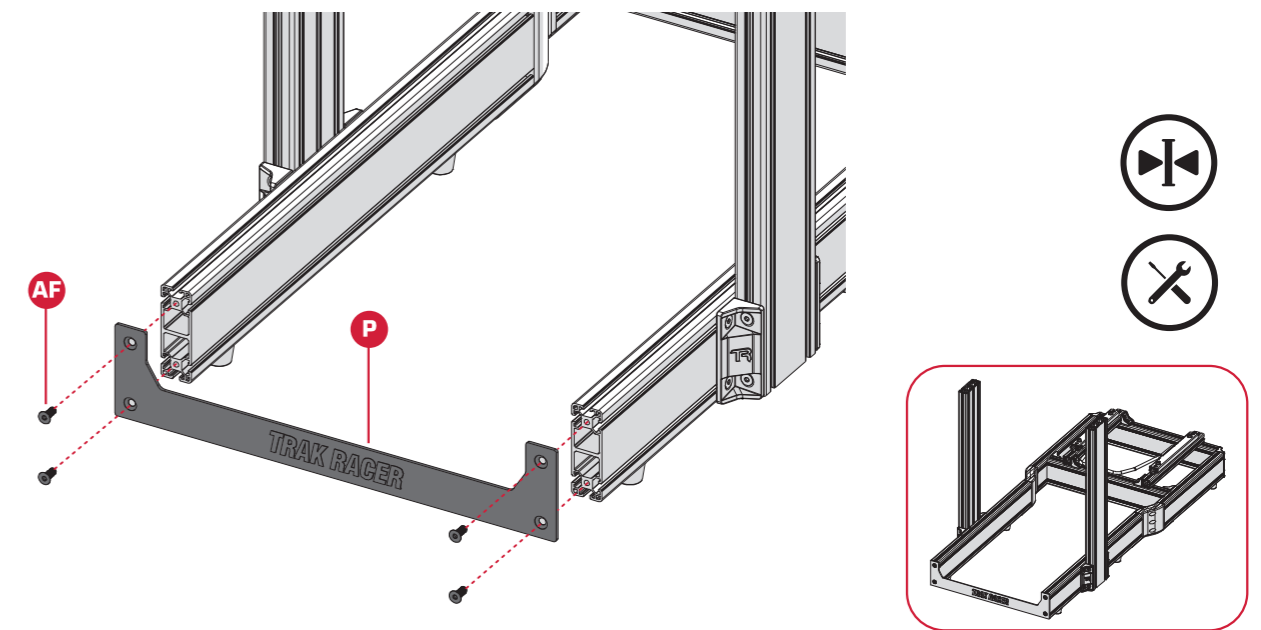
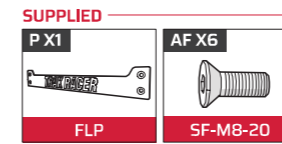

15

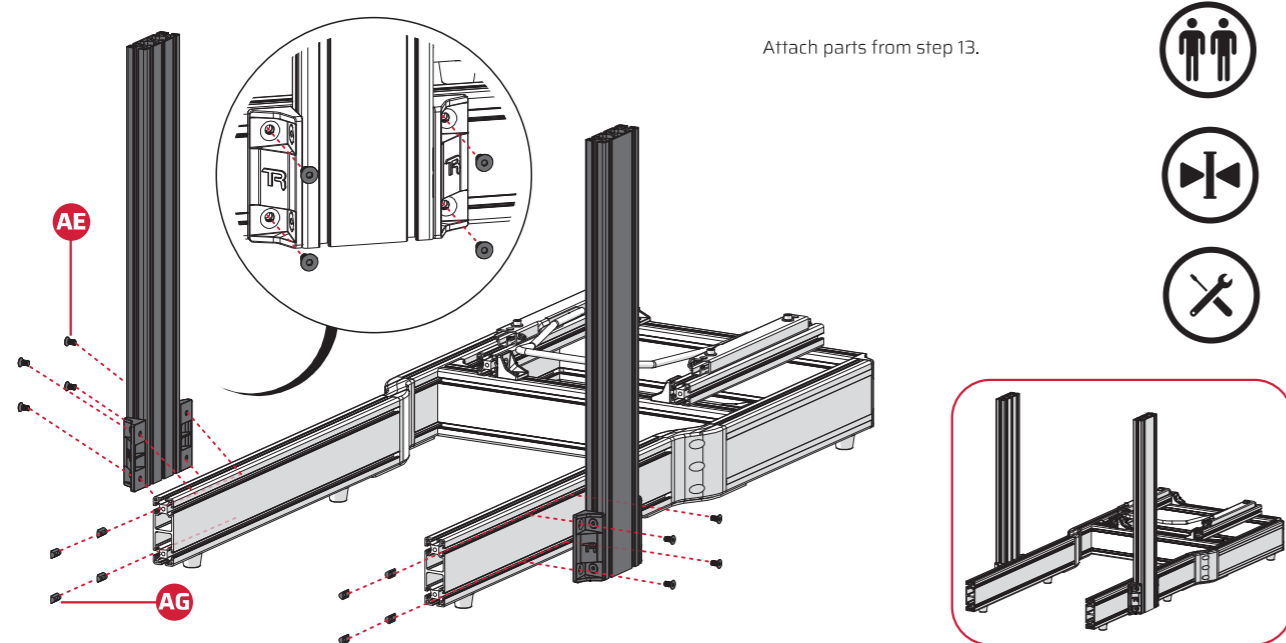
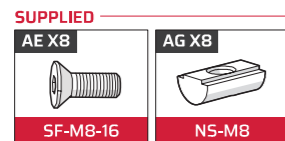

17

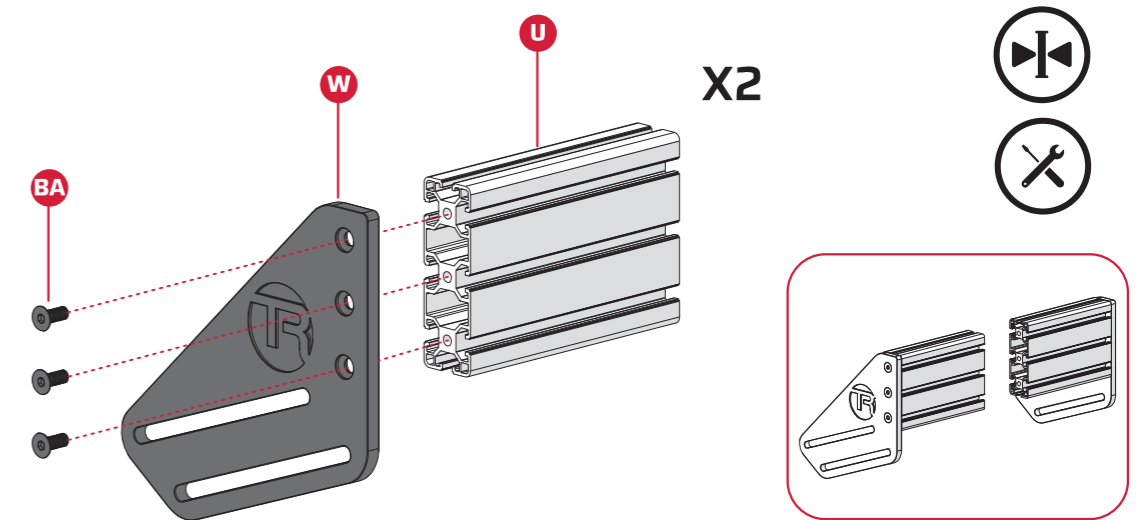
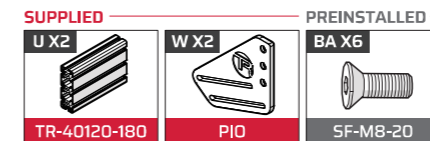

ASSEMBLY INSTRUCTIONS

TR120S

18

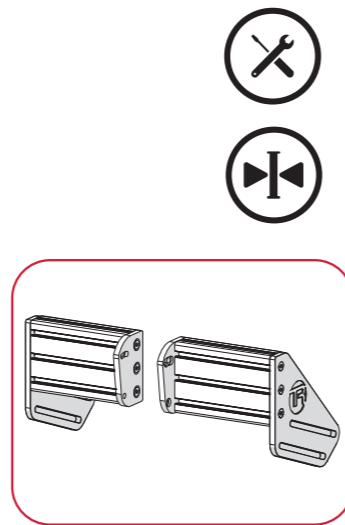
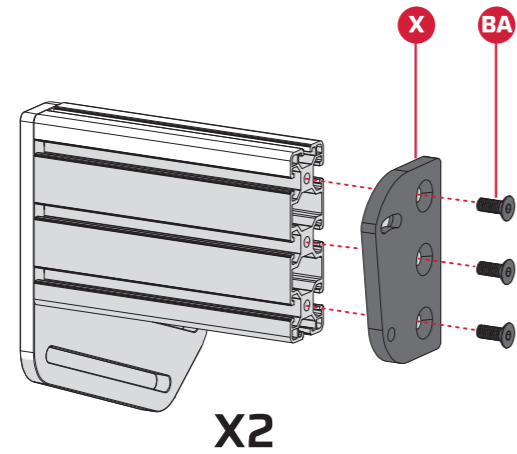
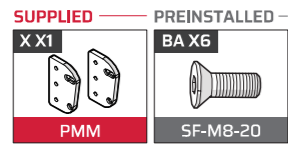

19

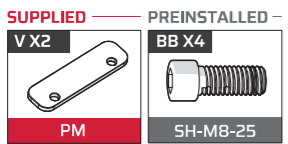

NOTE:
Thread screws just enough to hold PM in place
so screws donot protrude past PM plate.

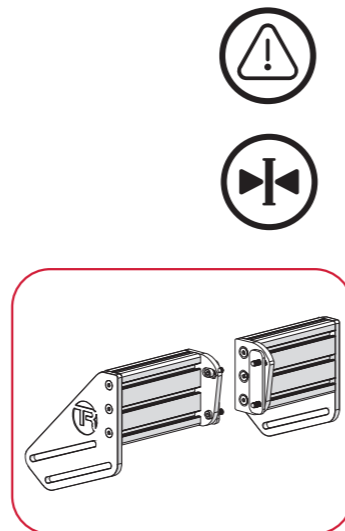
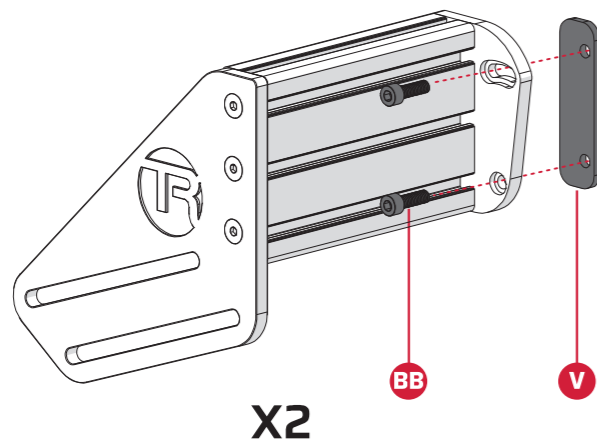

ASSEMBLY INSTRUCTIONS

TR120S

20

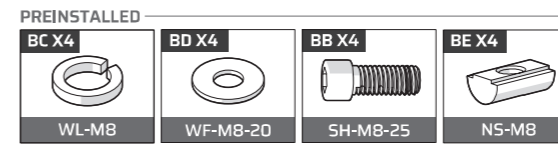

NOTE:
Adjust position after wheelbase and seat
installation.

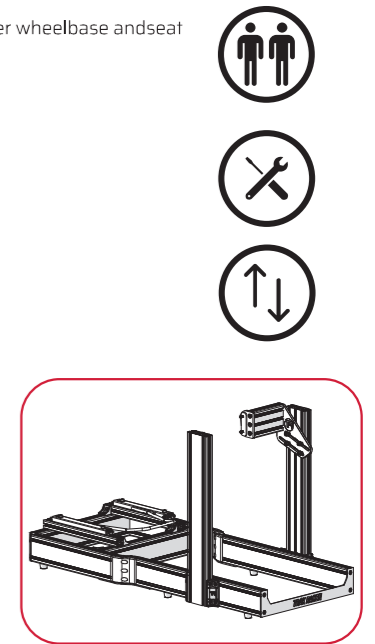
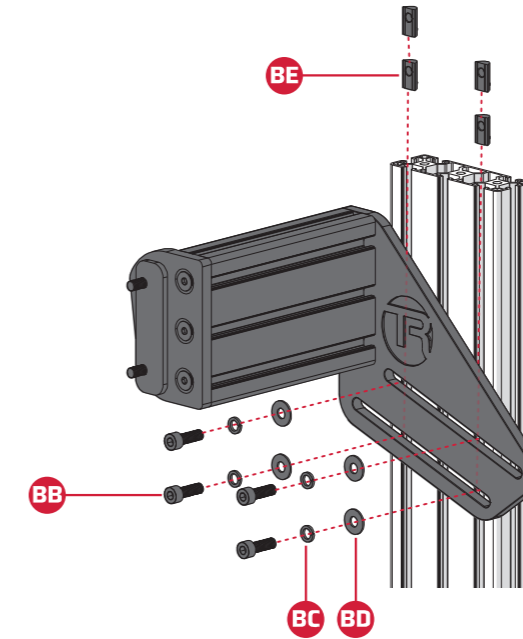

21

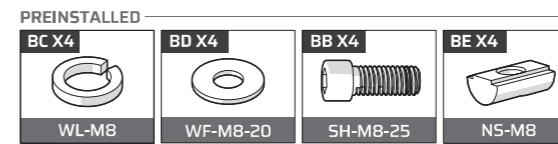

NOTE:
Adjust position after wheelbase and seat
installation.

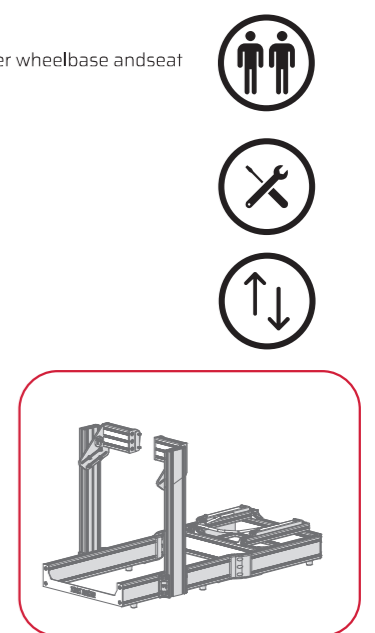
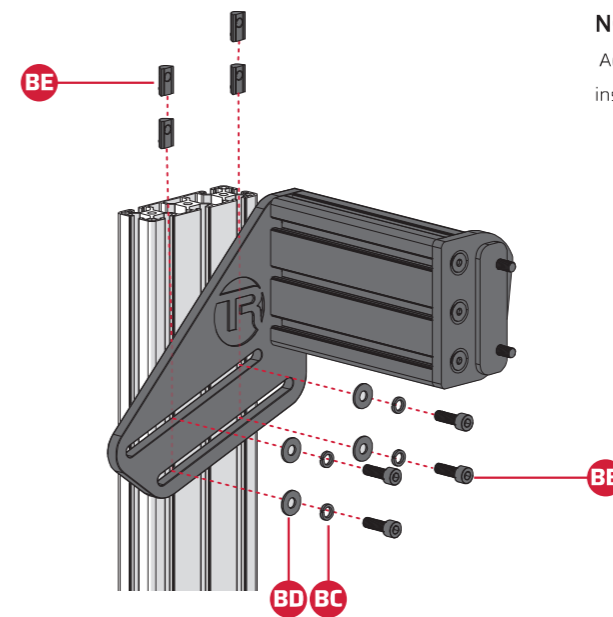

ASSEMBLY INSTRUCTIONS

TR120S

22

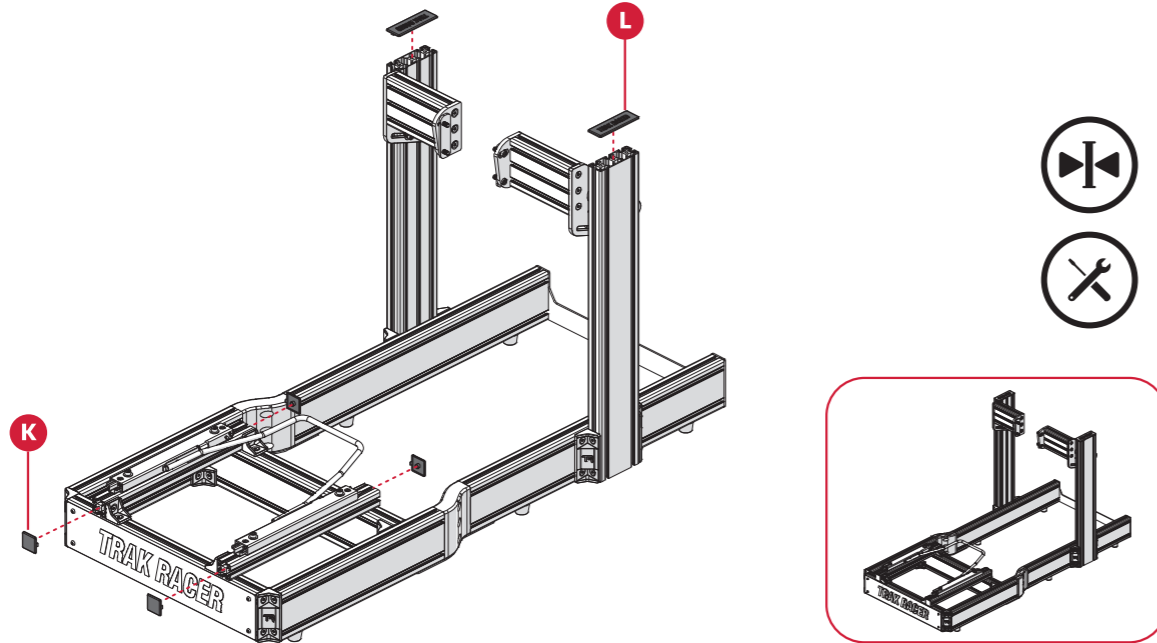
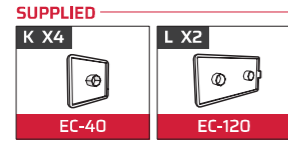

23

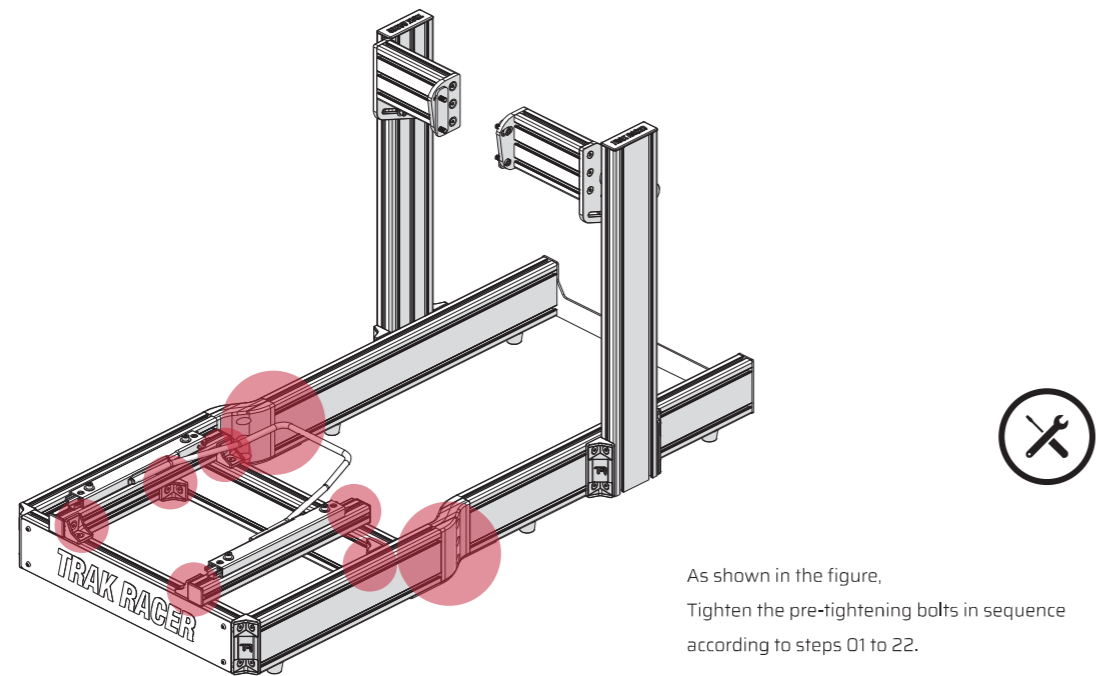

As shown in the figure,
Tighten the pre-tightening bolts in sequence
according to steps 01 to 22.

ASSEMBLY INSTRUCTIONS

TR120S

24

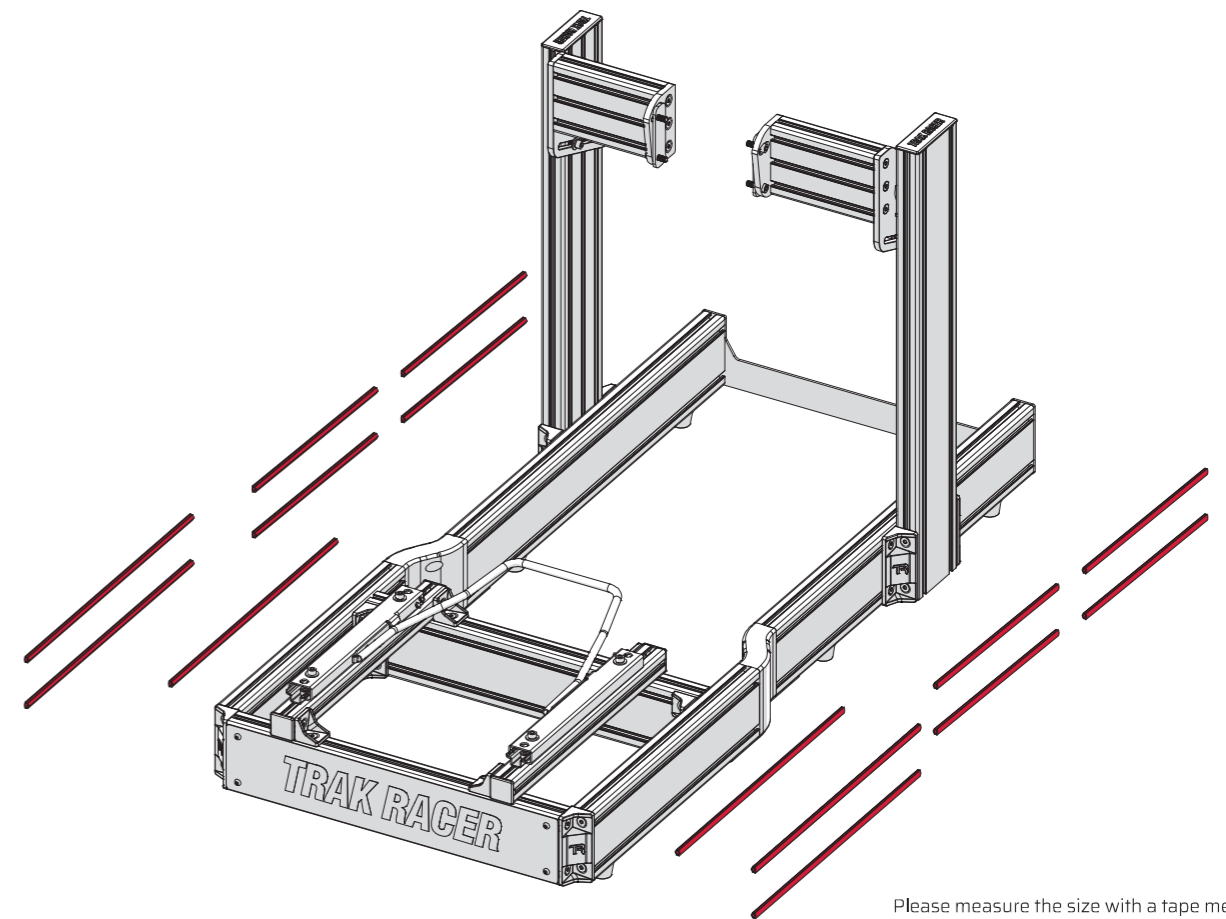
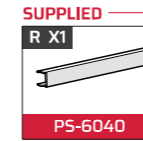

Please measure the size with a tape measure,
then cut it out with scissors and insert it into the
corresponding position.

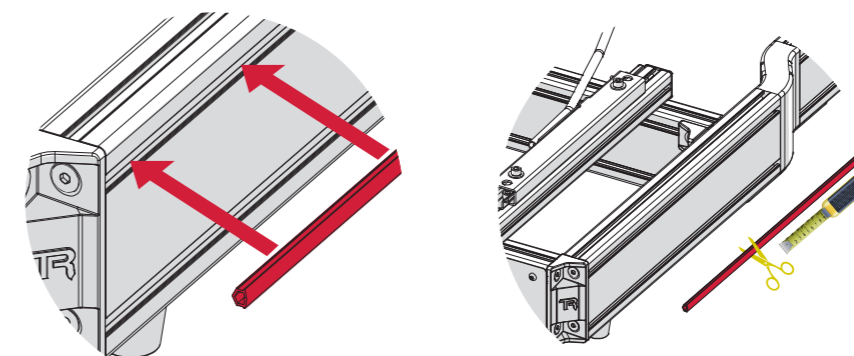

FINISHED PRODUCT

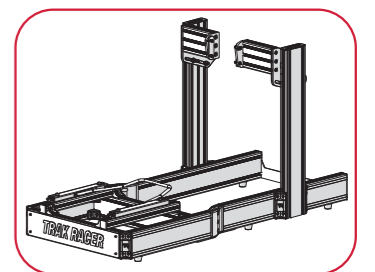

PEDAL OPTIONS

Please skip to the pages corresponding to the wheelbase mounting method you have chosen for your TR1605 rig.

OPTION 1

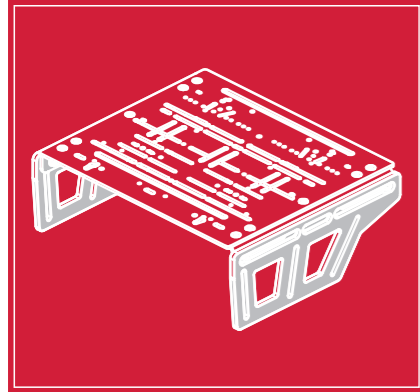

BRAKE PEDAL

TR80-PBPL2

OPTION 2

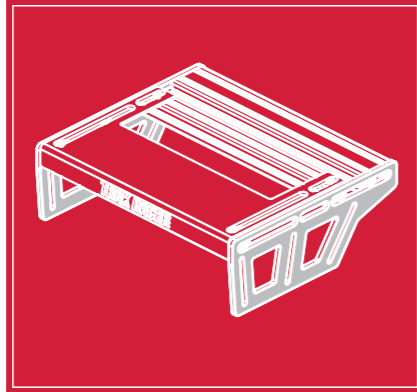

BRAKE PEDAL

TR80-PBAL2

OPTION 3

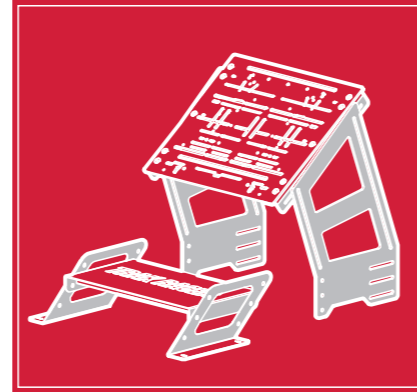

BRAKE PEDAL

TR80-HYPL2

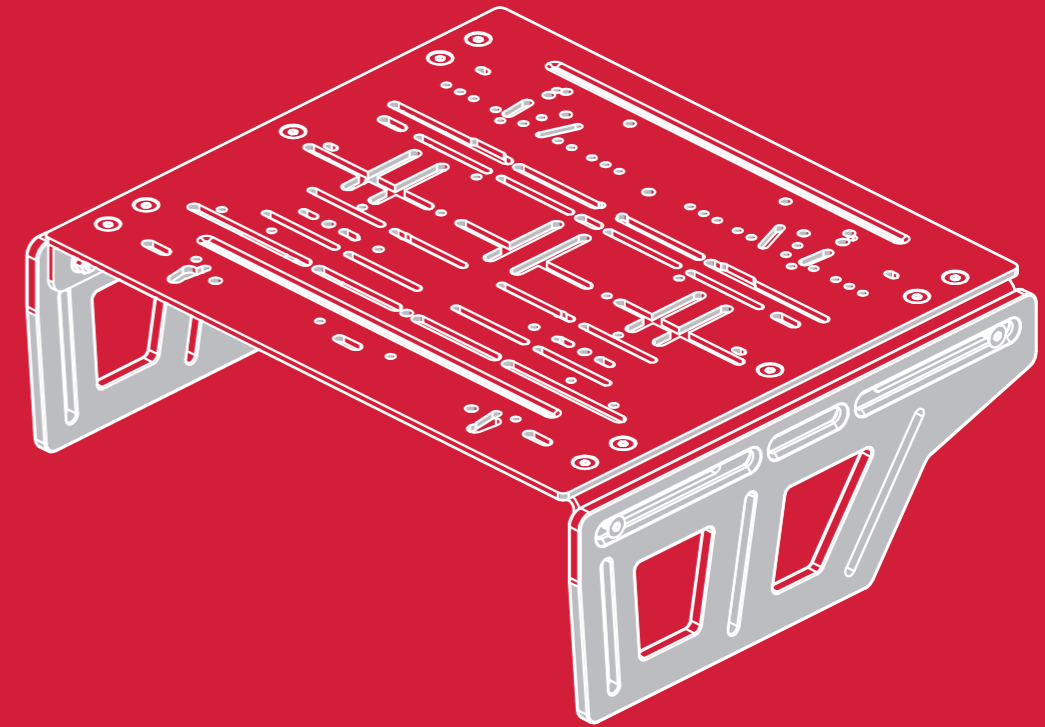

BRAKE PEDAL

Assembly Guide

TR80-PBPL2

TR80-PBPL2 PART LIST

ACCESSORIES (NOTE: Extra hardware may be included as spare parts)

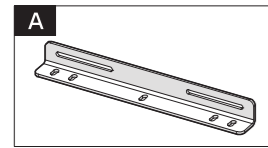

Pedal Plate Connector
TR80-PPC **X2**

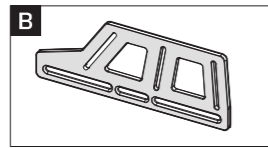

Pedal Plate Side Mount
TR80-PPSM **X2**

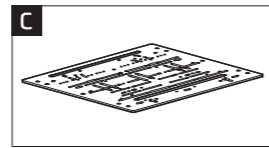

Pedal Plate
TR80-PP **X1**

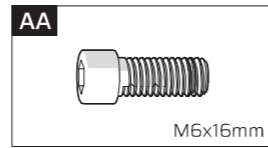

Hex Screw
SH-M6-16 **X4**

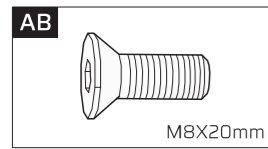

Screw (Flat)
SF-M8-20 **X18**

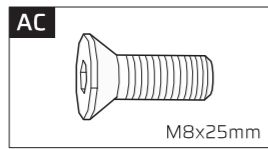

Screw (Flat)
SF-M8-25 **X8**

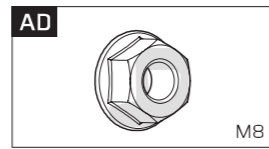

Flange Nut
NF-M8 **X18**

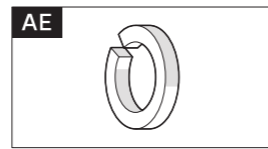

Lock Washer
WL-M8 **X4**

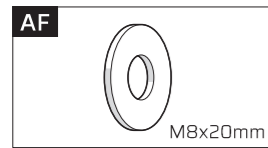

Washer (Flat)
WF-M8-20 **X4**

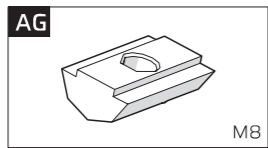

Ball Bearing Nut
NS-M8 **X4**

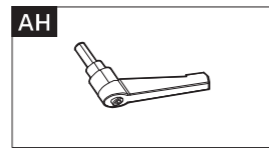

Offset Hex Key
OHK-M8-25 **X4**

NOTE:
Use screws and washers included
in the TR120S assembly.

ASSEMBLY INSTRUCTIONS

TR120S--TR80-PBAL2

01

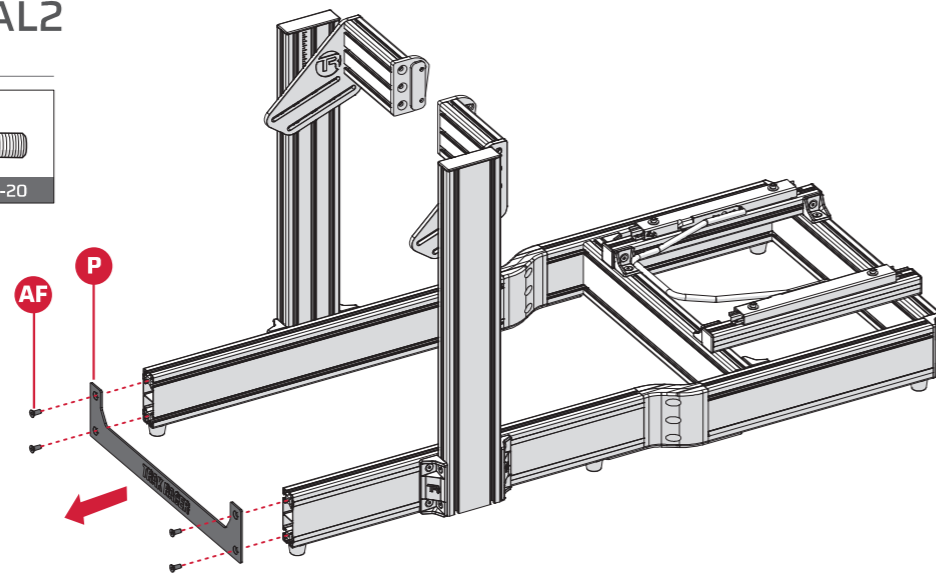
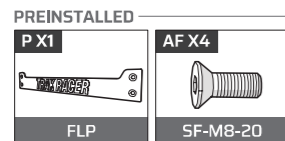

NOTE:
This step can also be changed
to start after Step 16 on page 15.

ASSEMBLY INSTRUCTIONS

TR120S--TR80-PBPL2

02

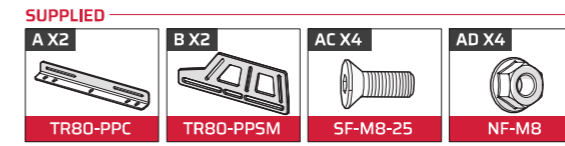

a

OPTION 1

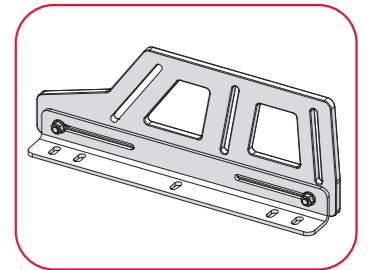
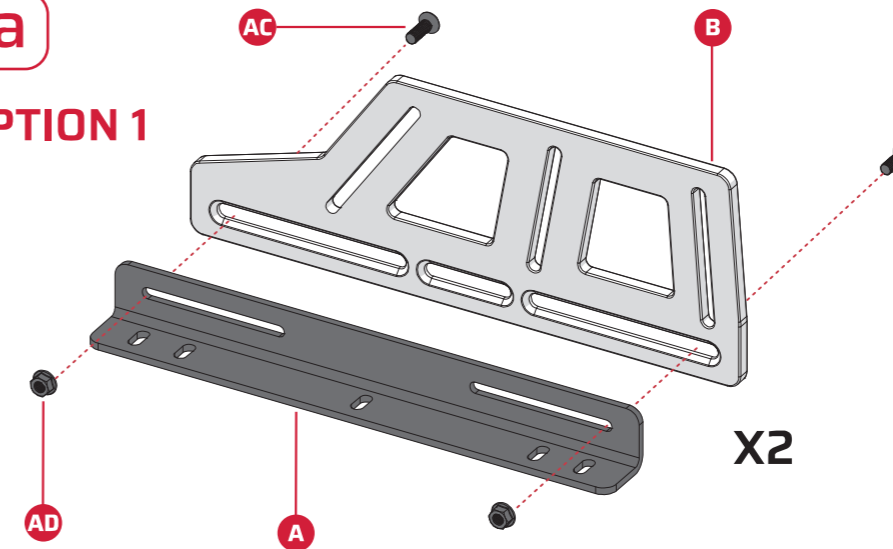

03

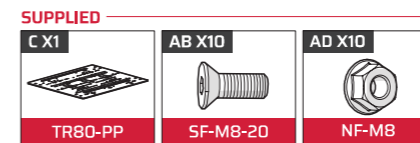

a

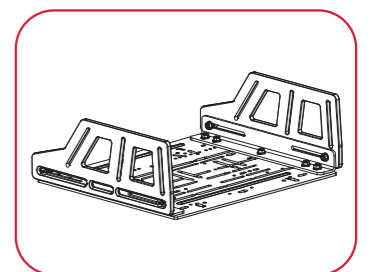
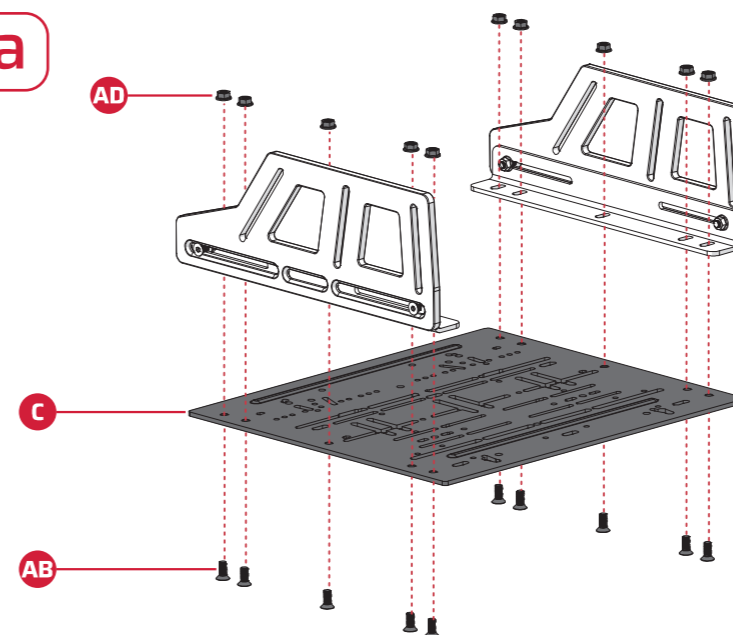

ASSEMBLY INSTRUCTIONS

TR120S--TR80-PBPL2

04



a

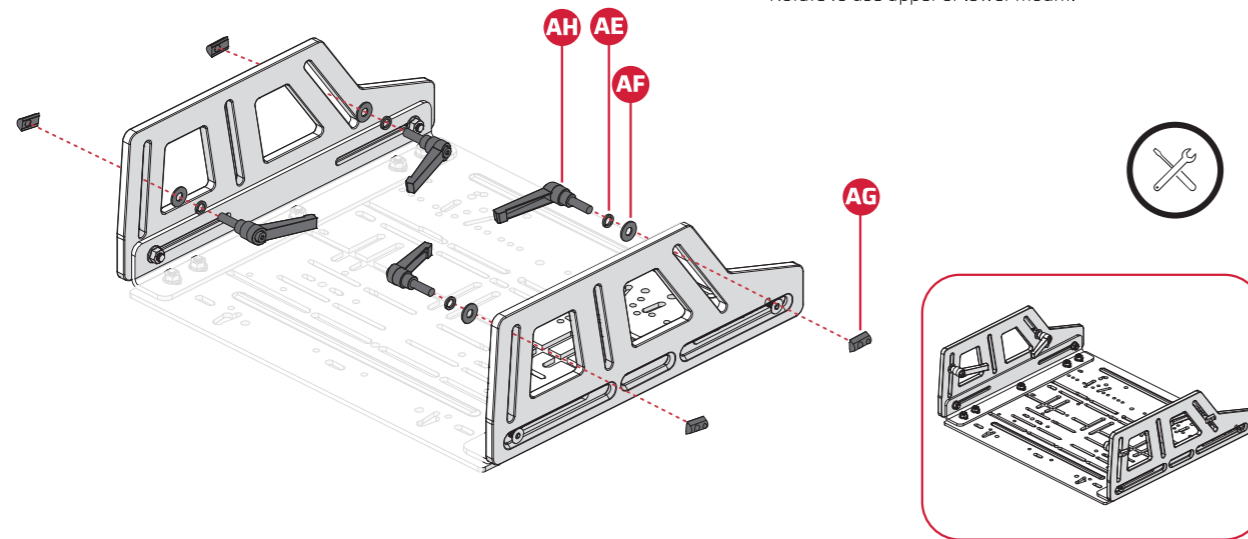

NOTE:

Rotate to use upper or lower mount.

05

a

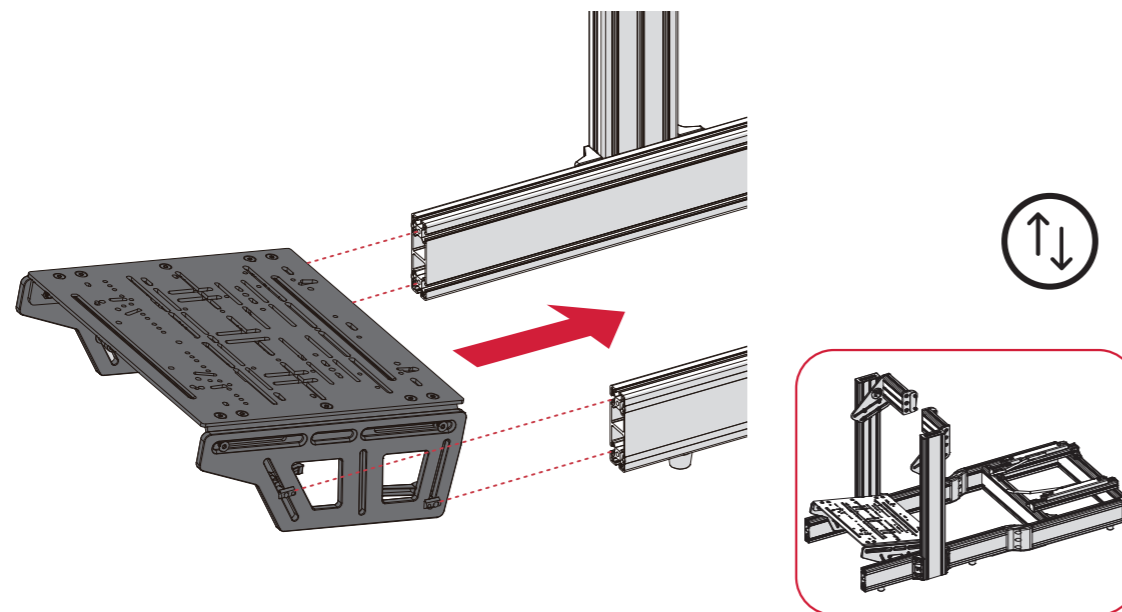

ASSEMBLY INSTRUCTIONS

TR120S--TR80-PBPL2

06

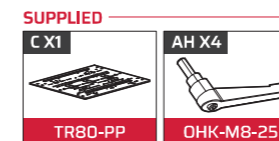

a

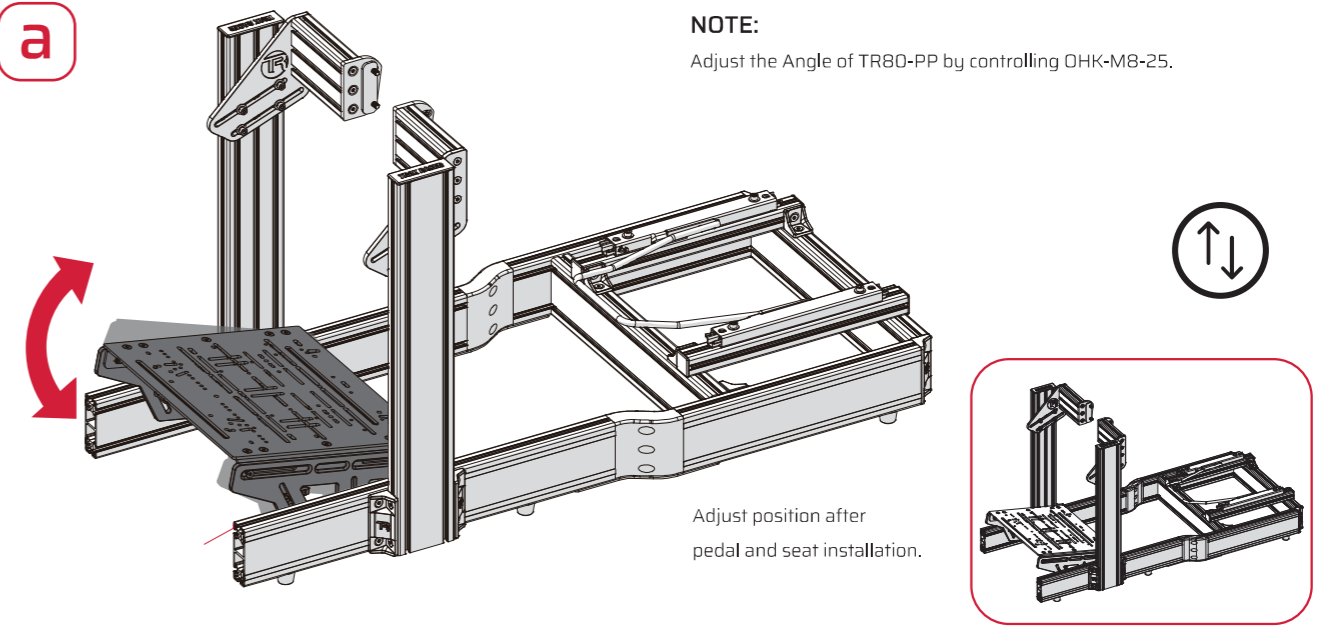

NOTE:

Adjust the Angle of TR80-PP by controlling OHK-M8-25.

Adjust position after
pedal and seat installation.

07

a

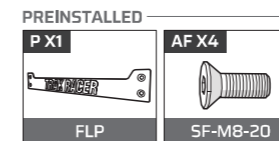

Tighten all the screws.

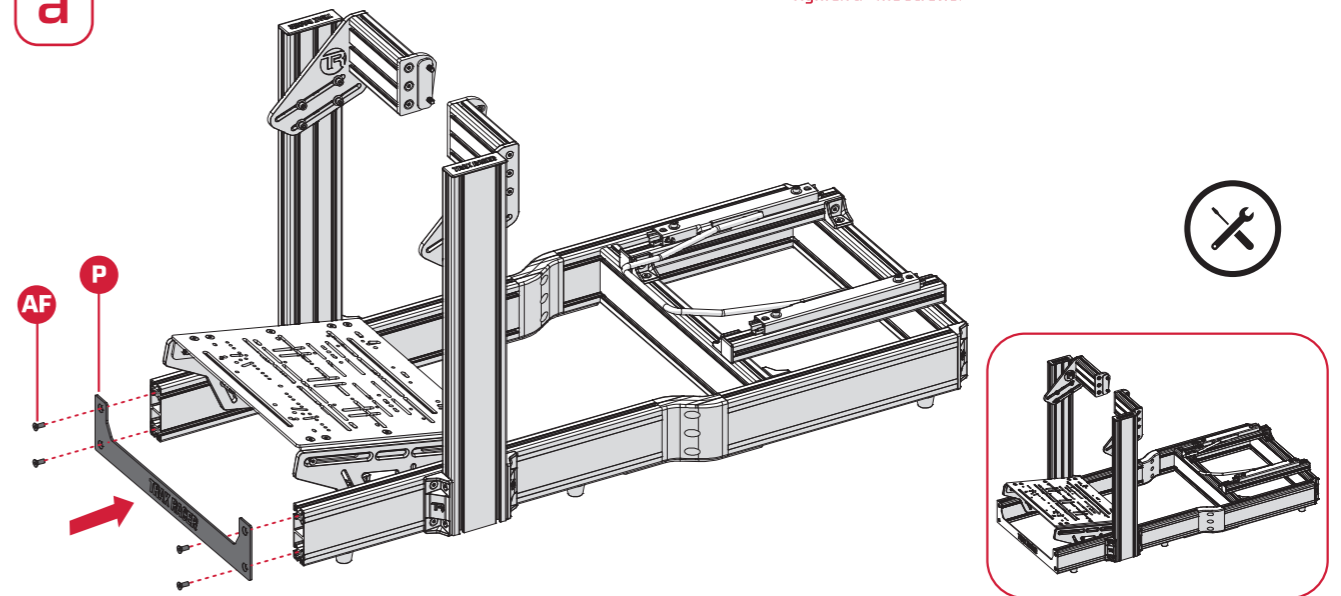

ASSEMBLY INSTRUCTIONS

TR120S--TR80-PBPL2

02

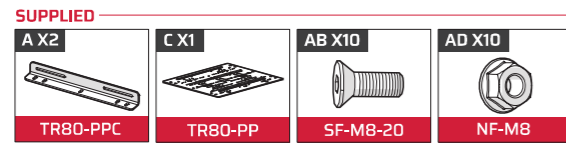

b

OPTION 2

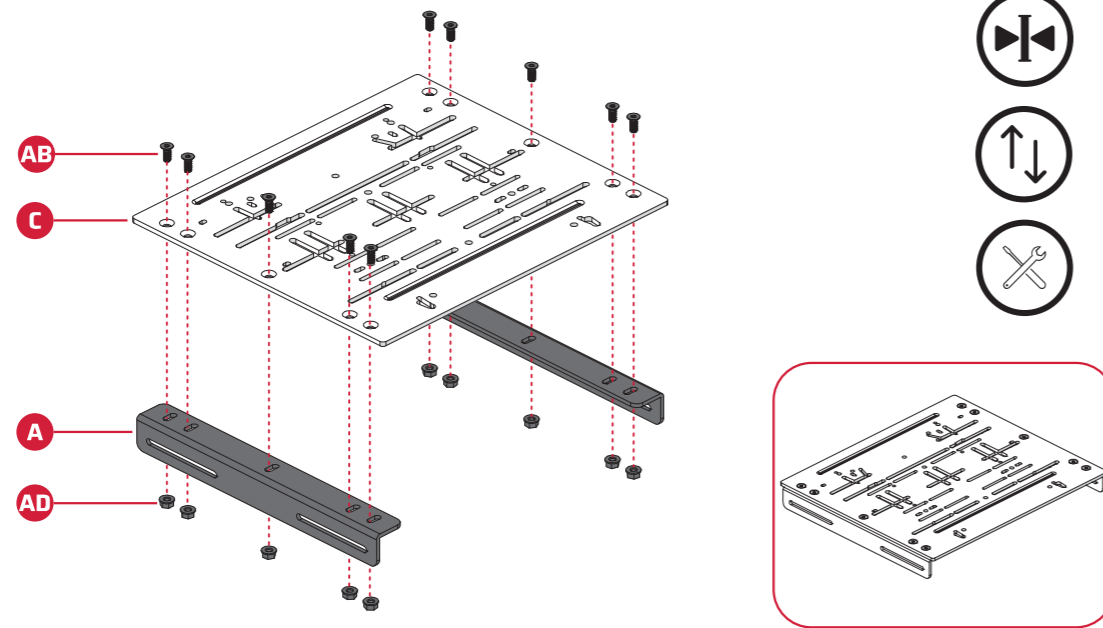

03

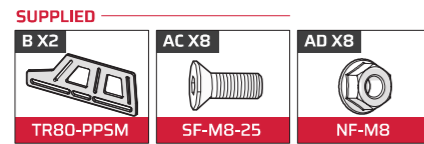

b

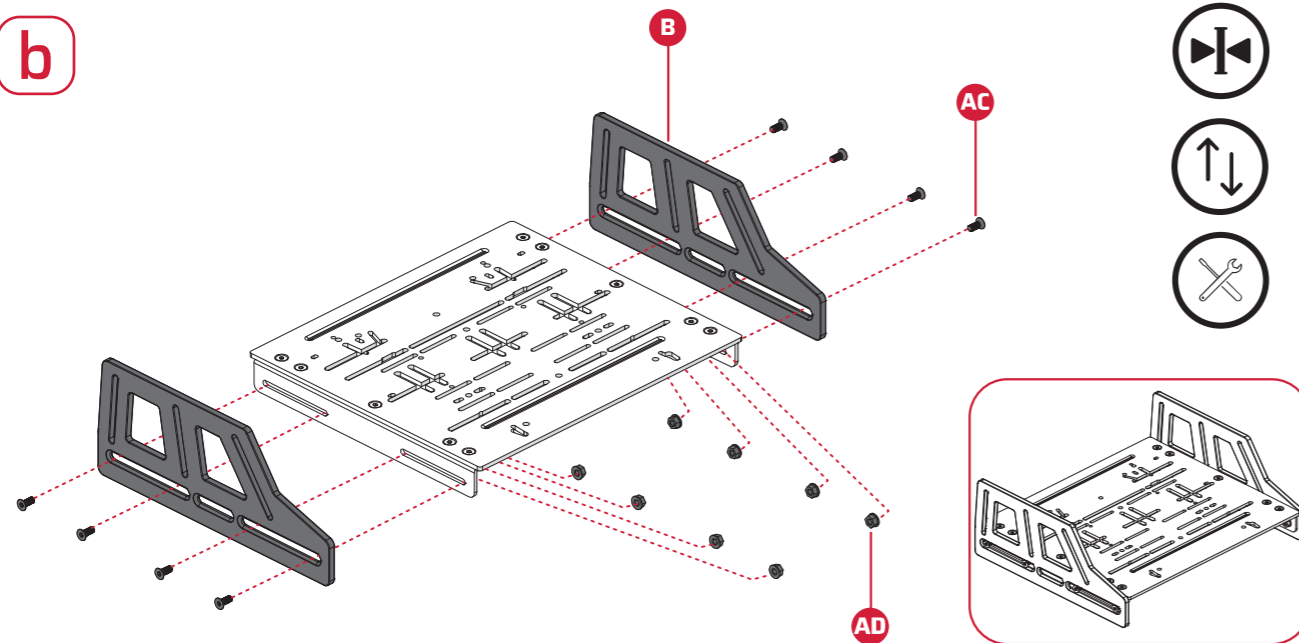

ASSEMBLY INSTRUCTIONS

TR120S--TR80-PBPL2

04

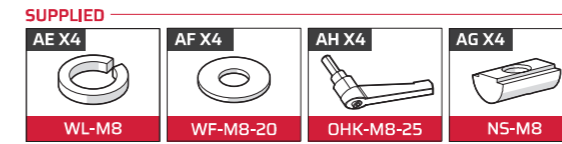

b

NOTE:
Rotate to use upper or lower mount.

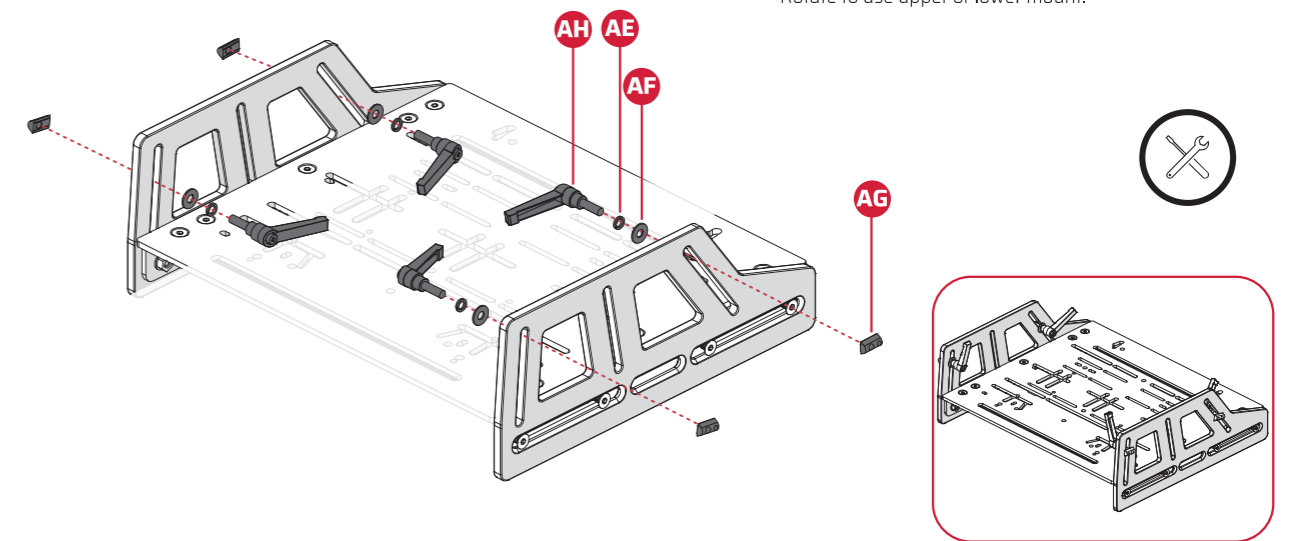

05

b

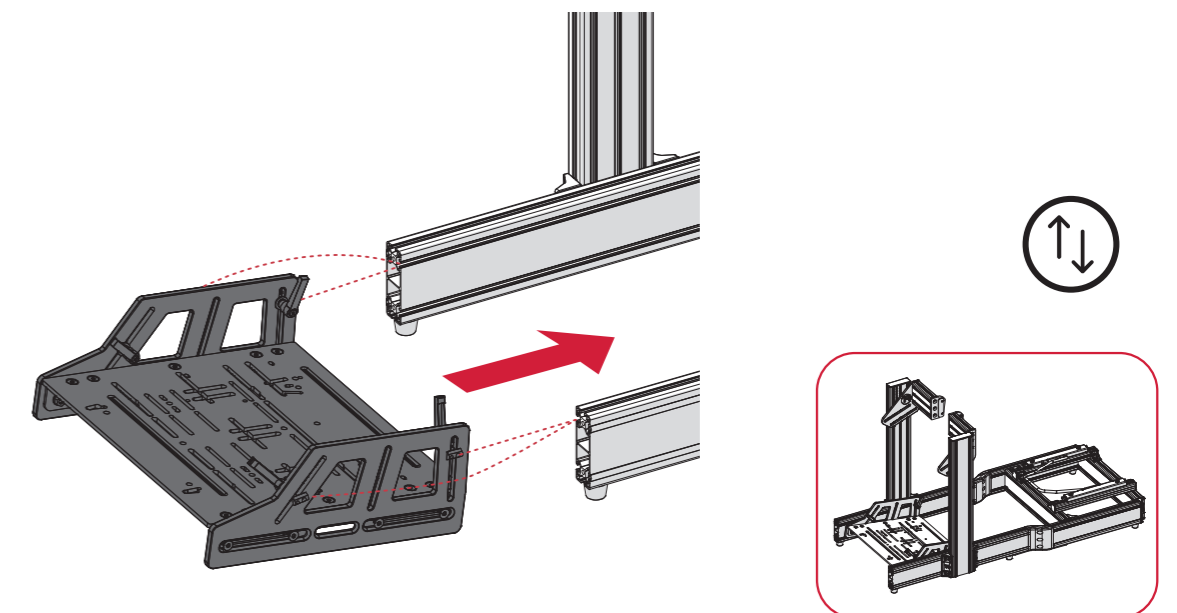

ASSEMBLY INSTRUCTIONS

TR120S--TR80-PBPL2



06

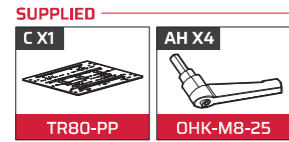

NOTE:
Adjust the Angle of TR80-PP by controlling OHK-M8-25.

b

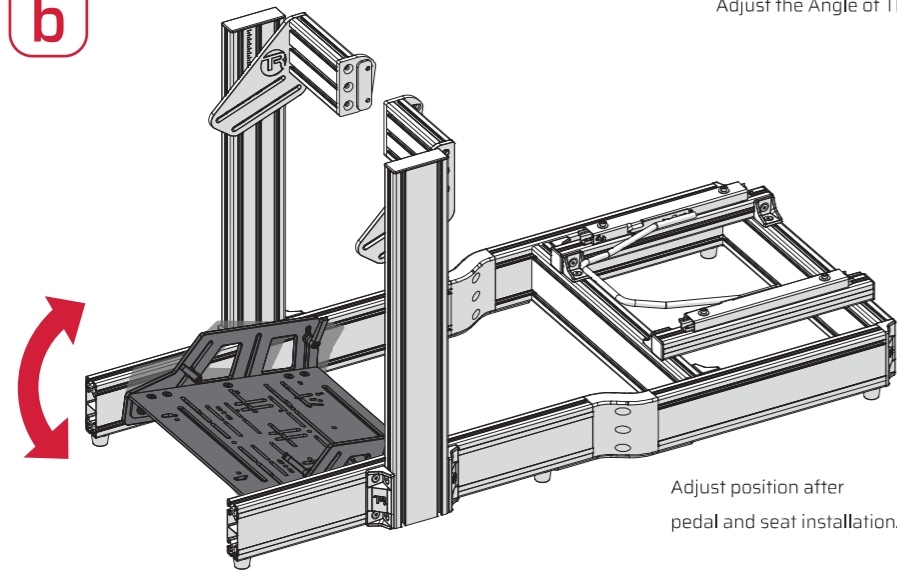

Adjust position after pedal and seat installation.

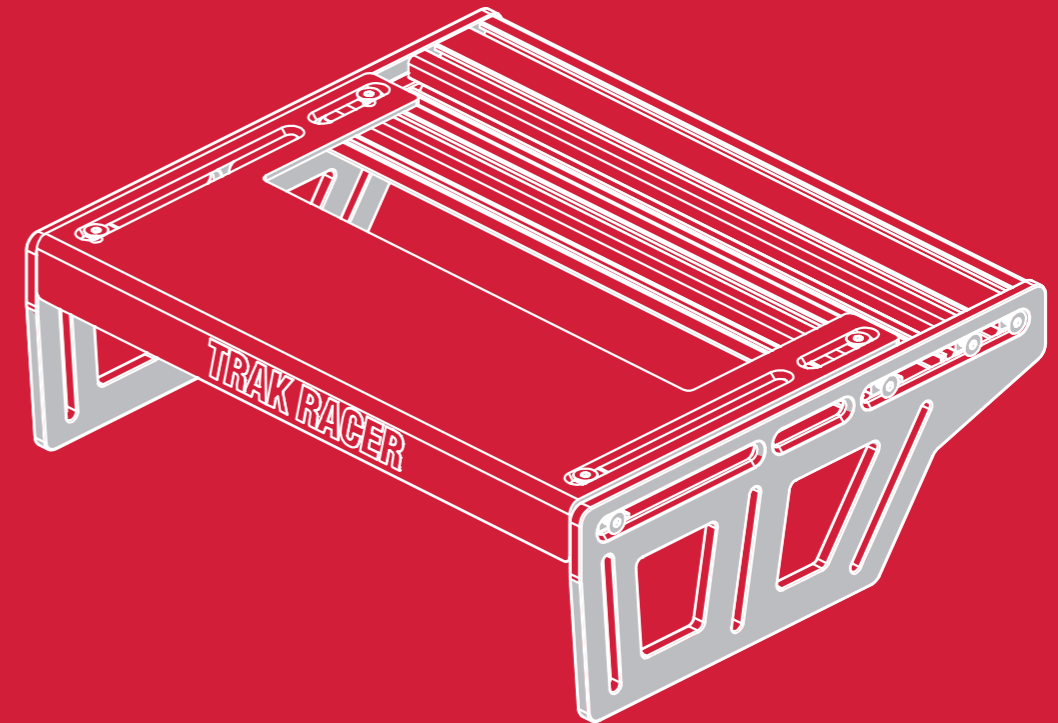
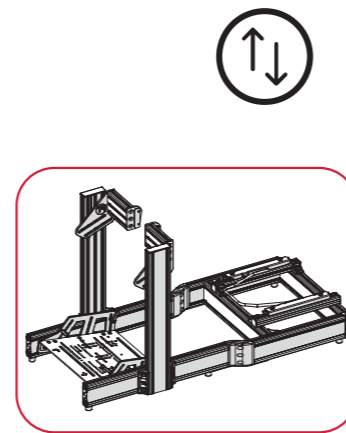

07

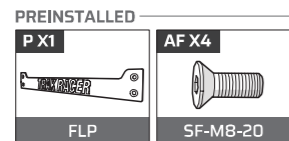

NOTE:
After installing the pedal, you can also proceed with the installation from step 17 on page 15.

b

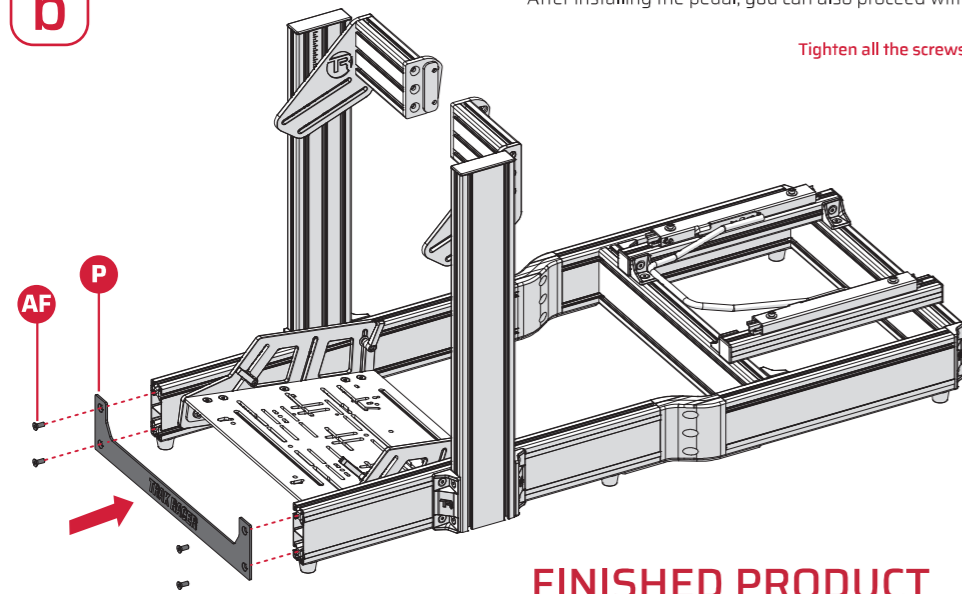

Tighten all the screws.

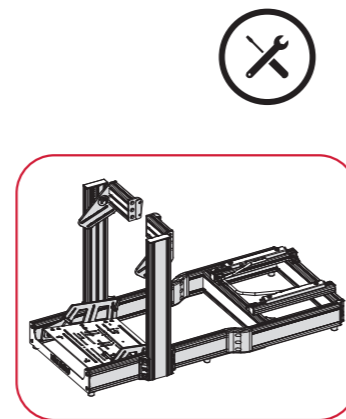

BRAKE PEDAL

Assembly Guide

TR80-PBAL2

TR80-PBAL2 PART LIST

ACCESSORIES (NOTE: Extra hardware may be included as spare parts)

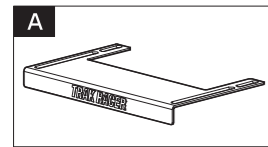

Heel Plate
TR80-HP-01 **X1**

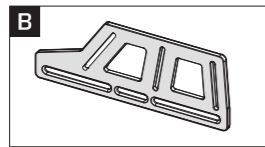

Pedal Plate Side Mount
TR80-PPSM **X2**

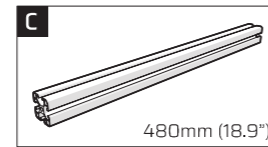

Aluminum Profile
TR-4040-480 **X2**

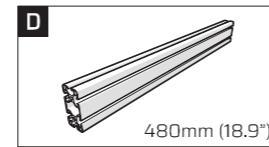

Aluminum Profile
TR-8040-480 **X1**

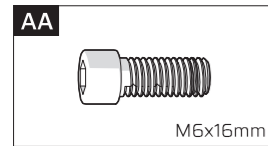

Hex Screw
SH-M6-16 **X12**

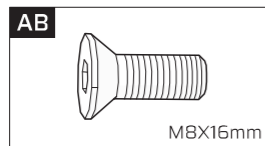

Screw (Flat)
SF-M8-16 **X8**

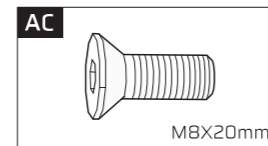

Screw (Flat)
SF-M8-20 **X8**

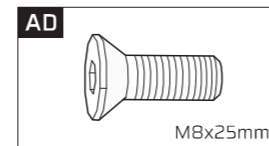

Screw (Flat)
SF-M8-25 **X8**

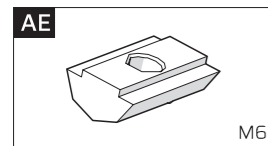

Ball Bearing Nut
NS-M6 **X12**

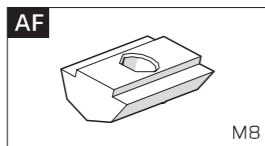

Ball Bearing Nut
NS-M8 **X12**

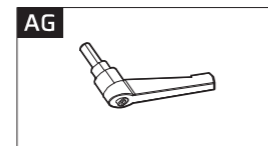

Offset Hex Key
OHK-M8-25 **X4**

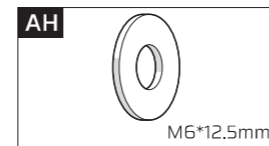

Washer (Flat)
WF-M6-12.5 **X12**

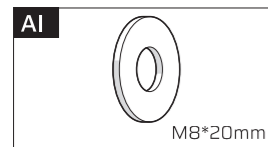

Washer (Flat)
WF-M8*20 **X12**

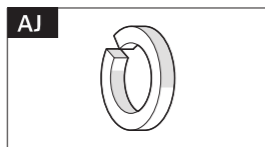

Lock Washer
WL-M6 **X4**

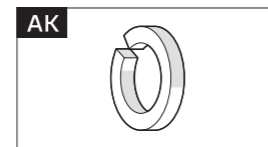

Lock Washer
WL-M8 **X4**

NOTE:
Use screws and washers included in the TR1205 assembly.

ASSEMBLY INSTRUCTIONS

TR1205--TR80-PBAL2

01

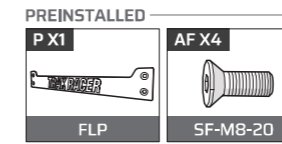

NOTE:
This step can also be changed to start after Step 16 on page 15.

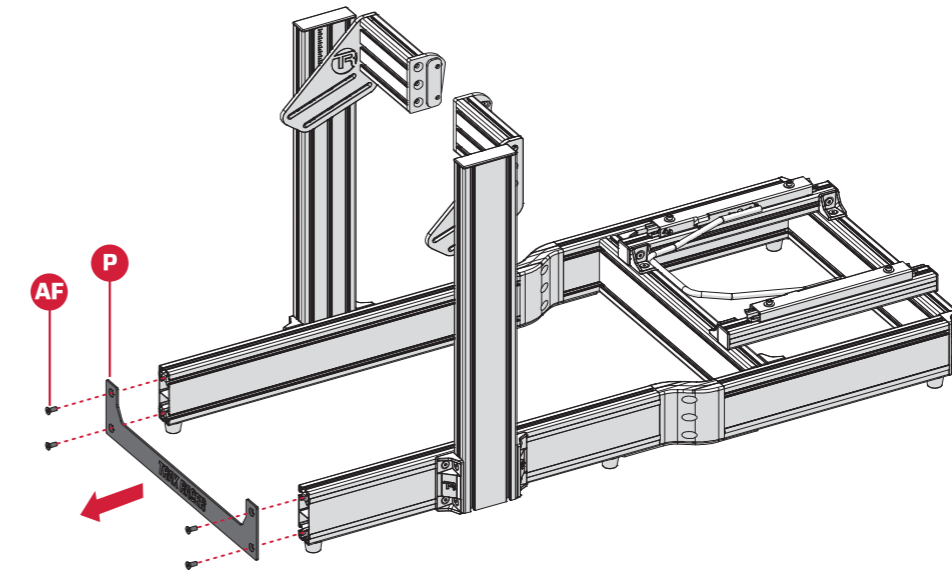

02



a

OPTION 1

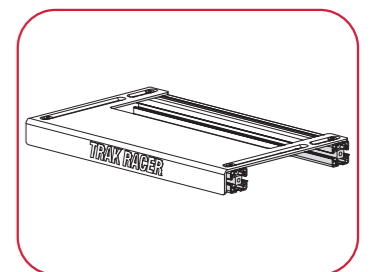
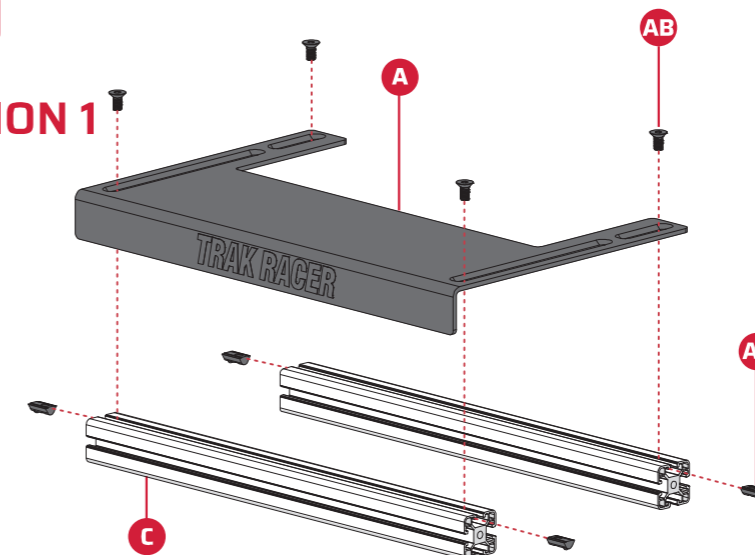

ASSEMBLY INSTRUCTIONS

TR120S--TR80-PBAL2

03



a

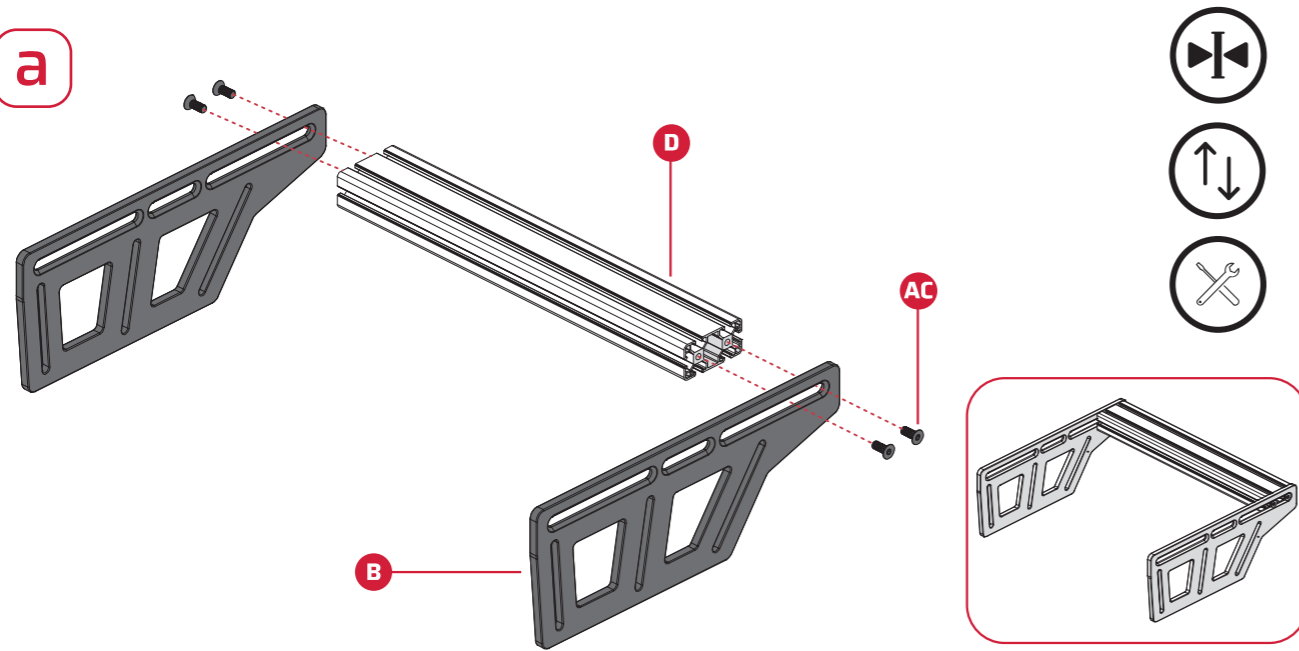

04

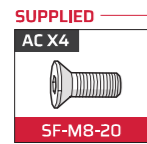

a

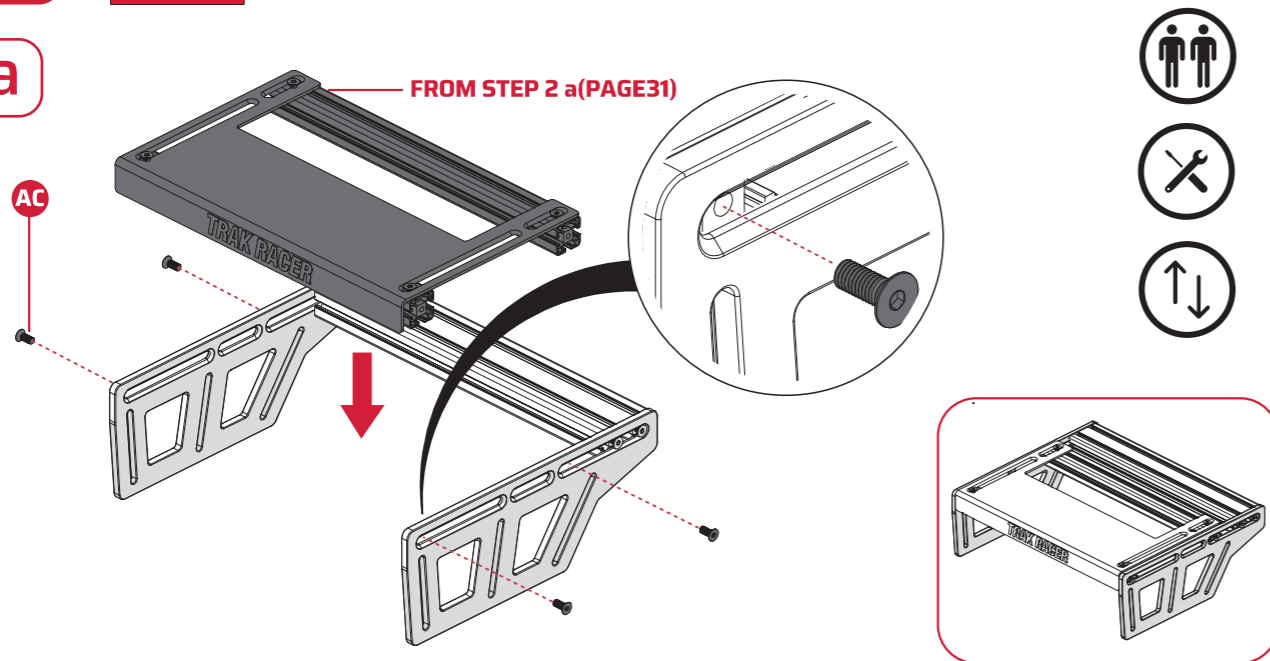

ASSEMBLY INSTRUCTIONS

TR120S--TR80-PBAL2

05

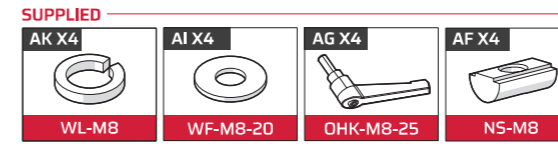

a

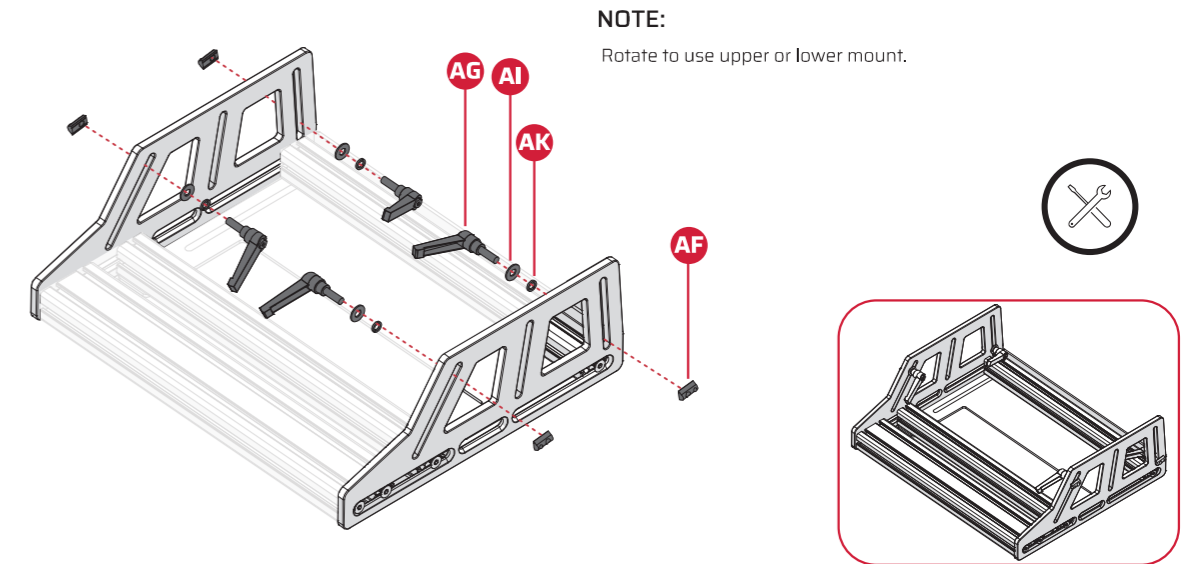

06

a

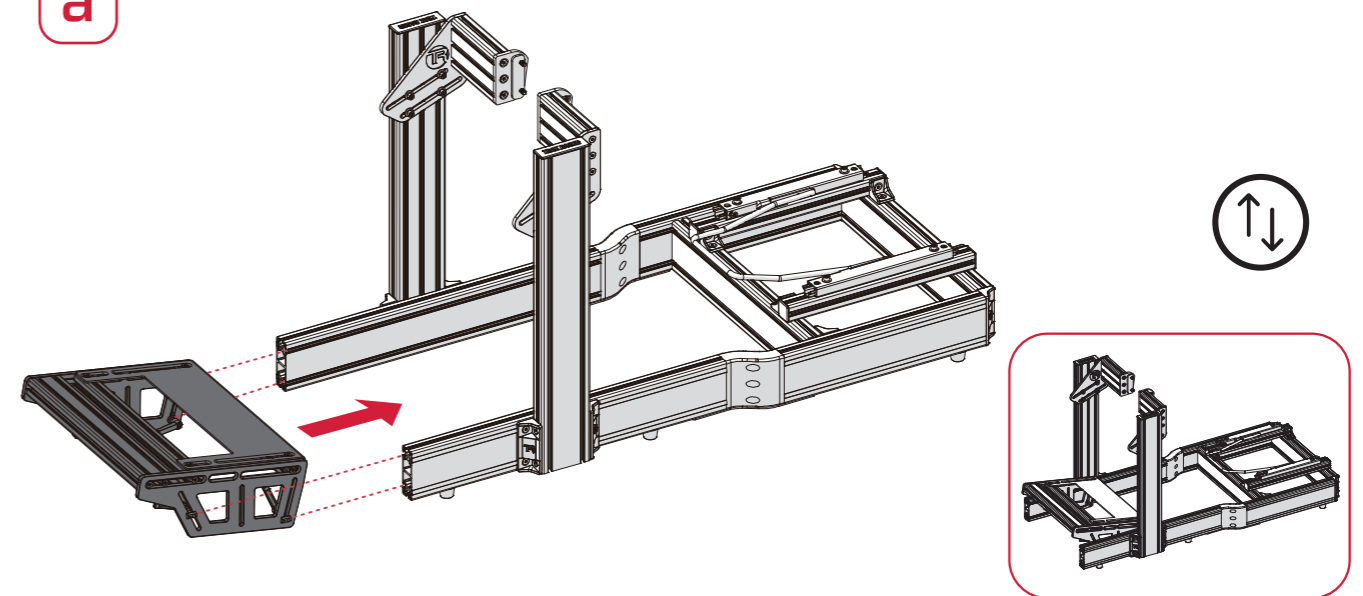

ASSEMBLY INSTRUCTIONS

TR120S--TR80-PBAL2

07

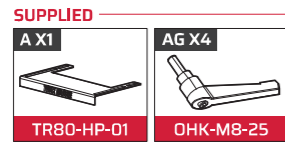

a

NOTE:

Adjust the Angle of TR80-HP-01 by controlling OHK-M8-25.

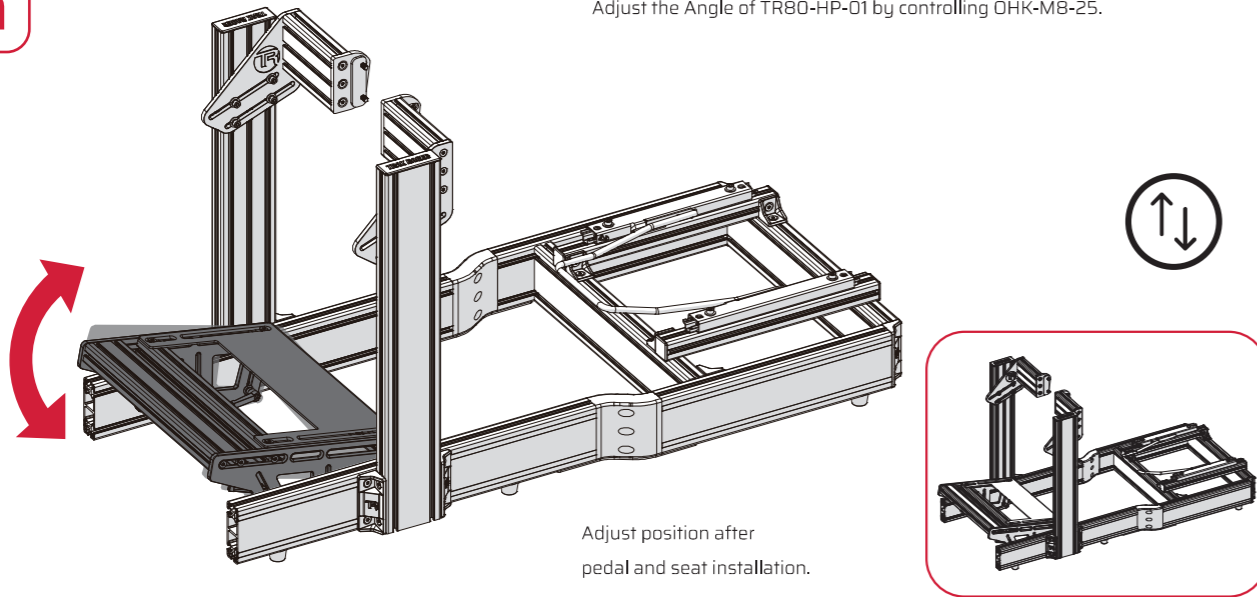

08

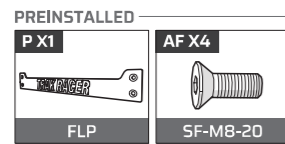

a

Tighten all the screws.

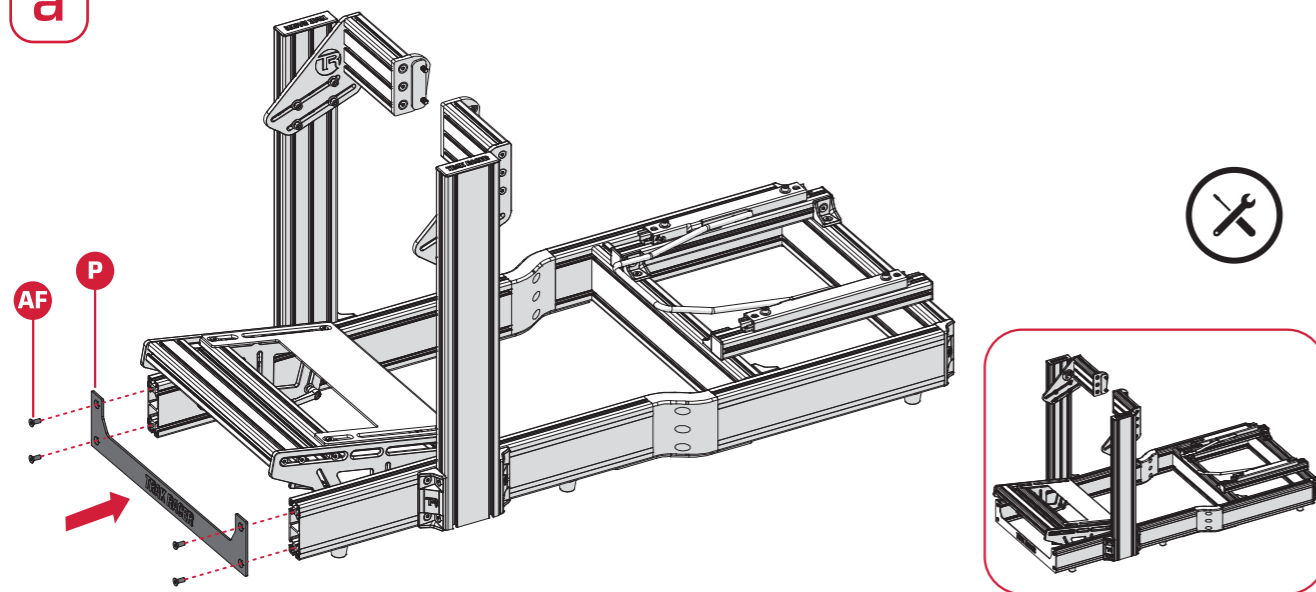

ASSEMBLY INSTRUCTIONS

TR120S--TR80-PBAL2

02



b

OPTION 2

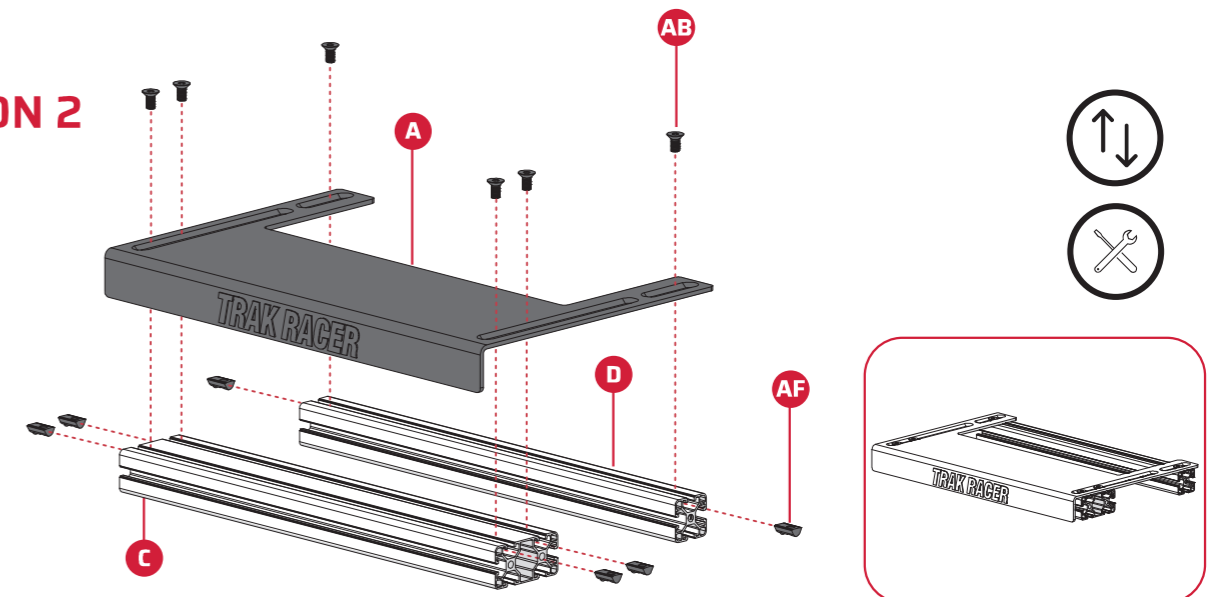

03



b

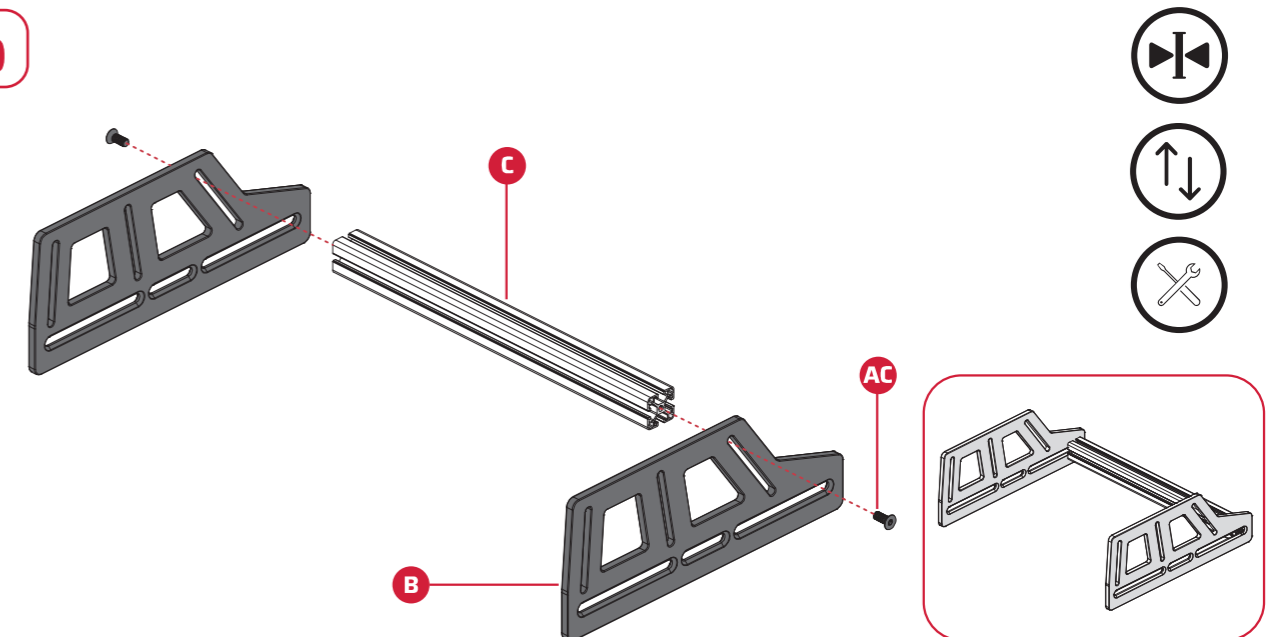

ASSEMBLY INSTRUCTIONS

TR120S--TR80-PBAL2

04

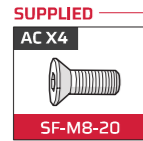

b

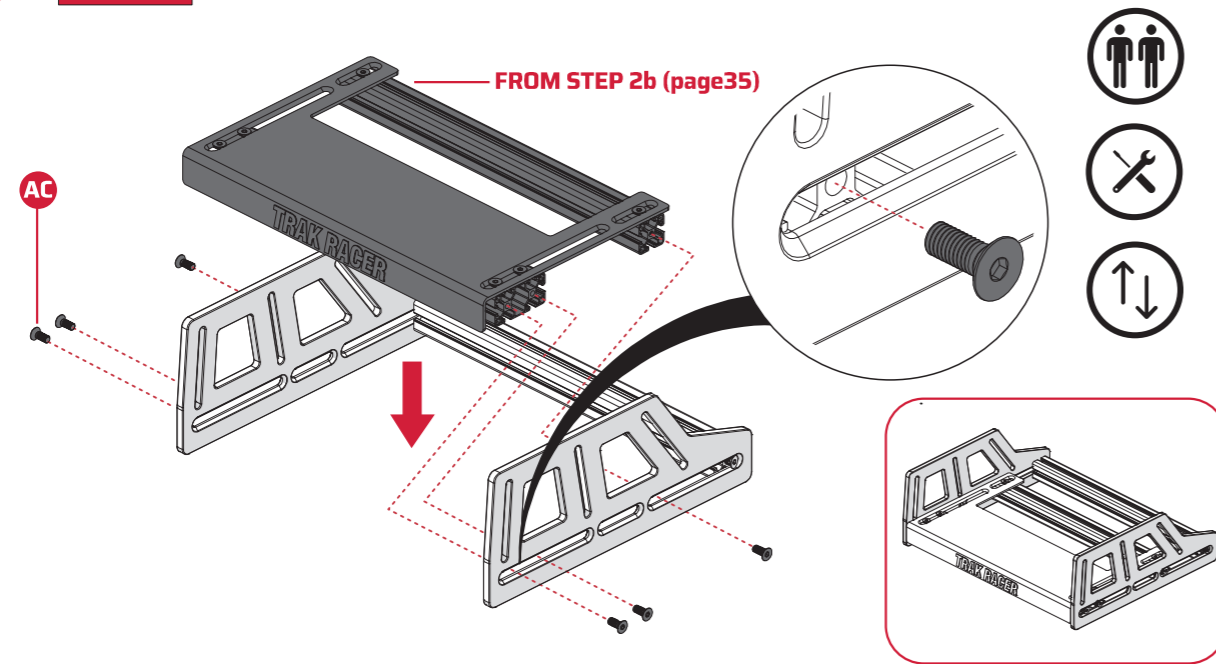

05

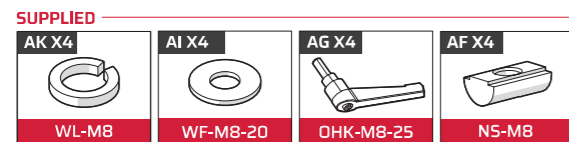

b

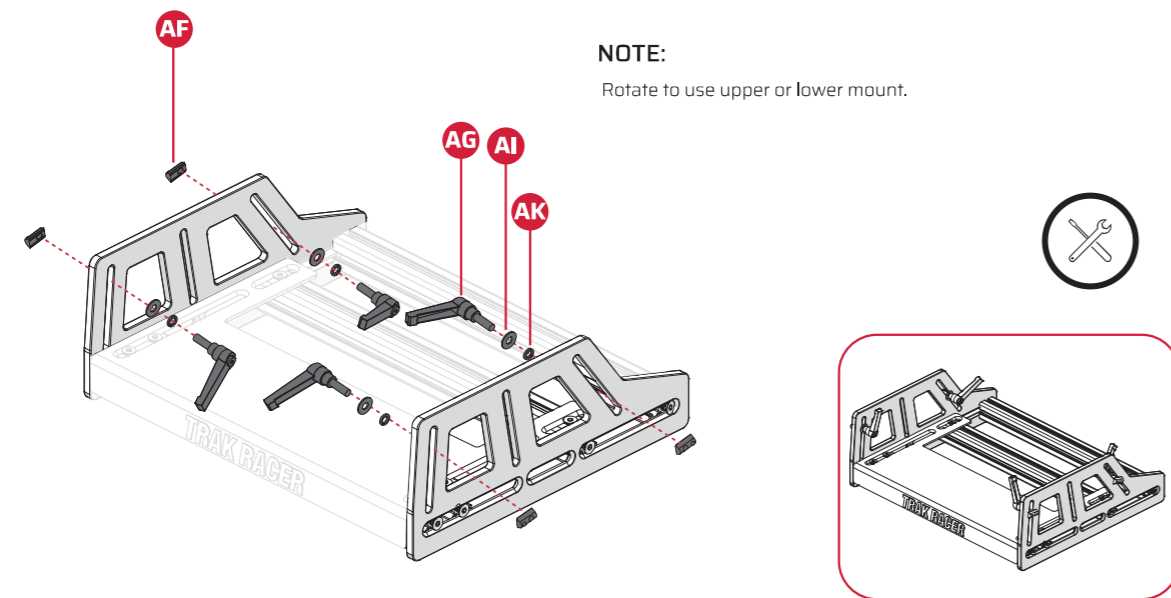

ASSEMBLY INSTRUCTIONS

TR120S--TR80-PBAL2

06

b

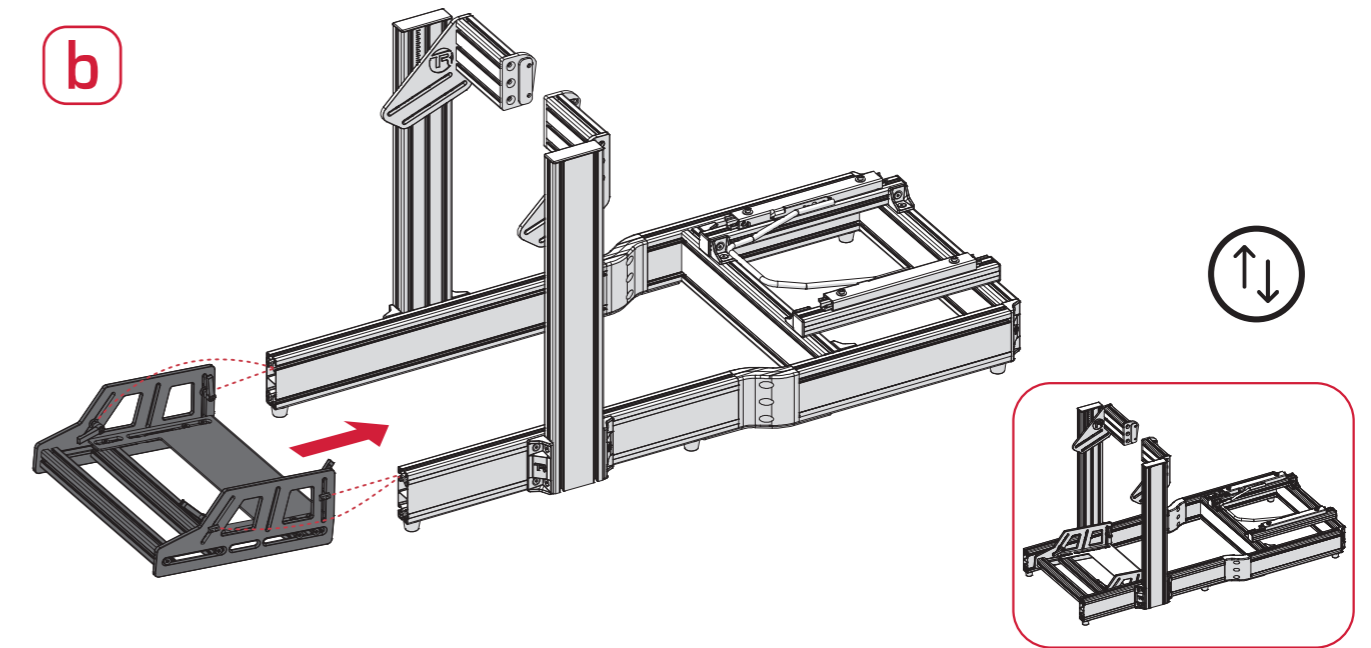

07

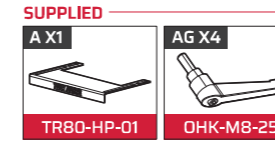

b

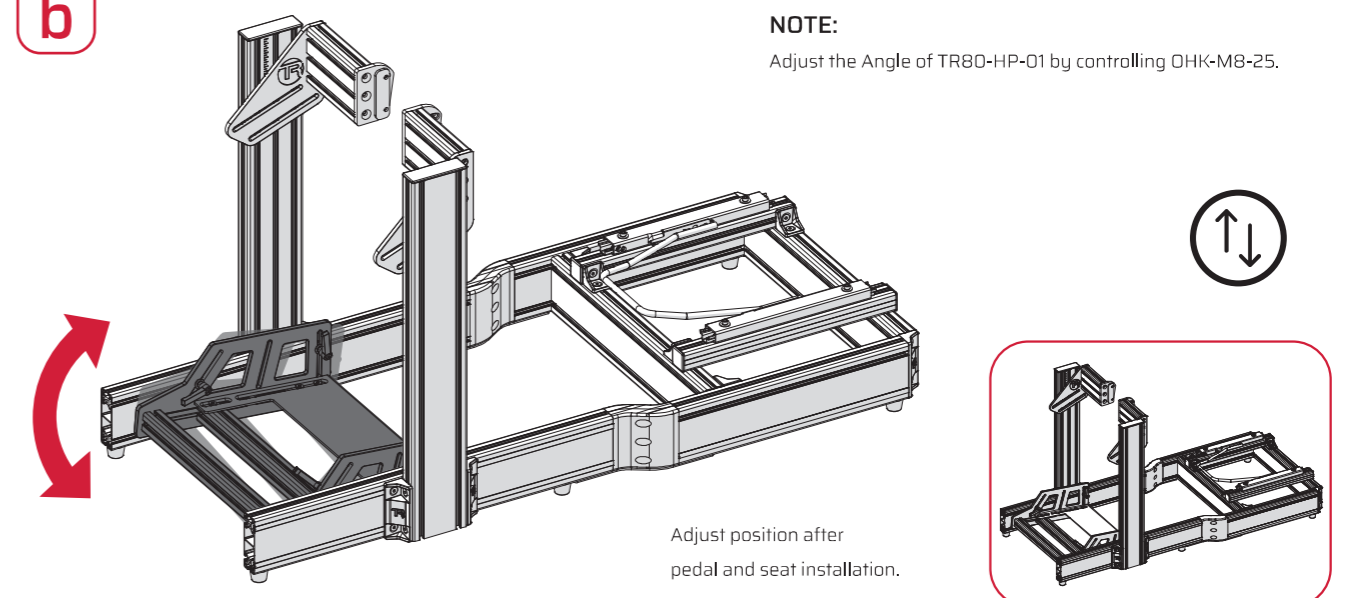

ASSEMBLY INSTRUCTIONS

TR120S--TR80-PBAL2

08

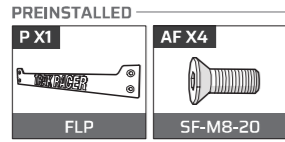

b

Tighten all the screws.

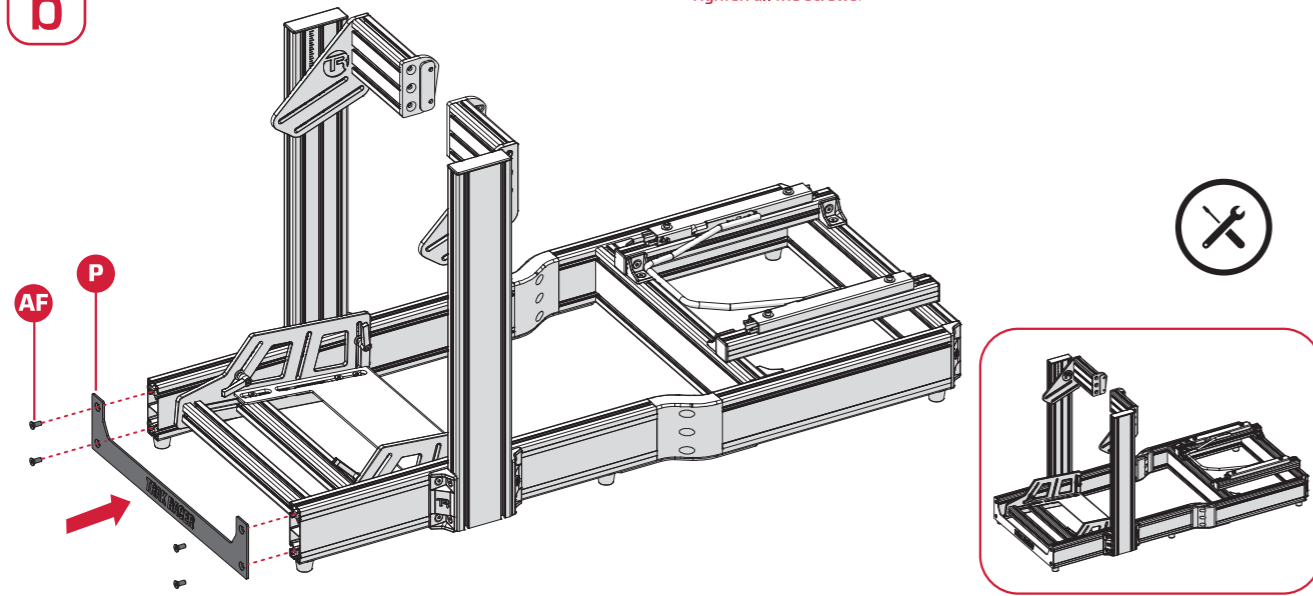

NOTE:

After installing the pedal, you can also proceed with the installation from step 17 on page 15.

FINISHED PRODUCT

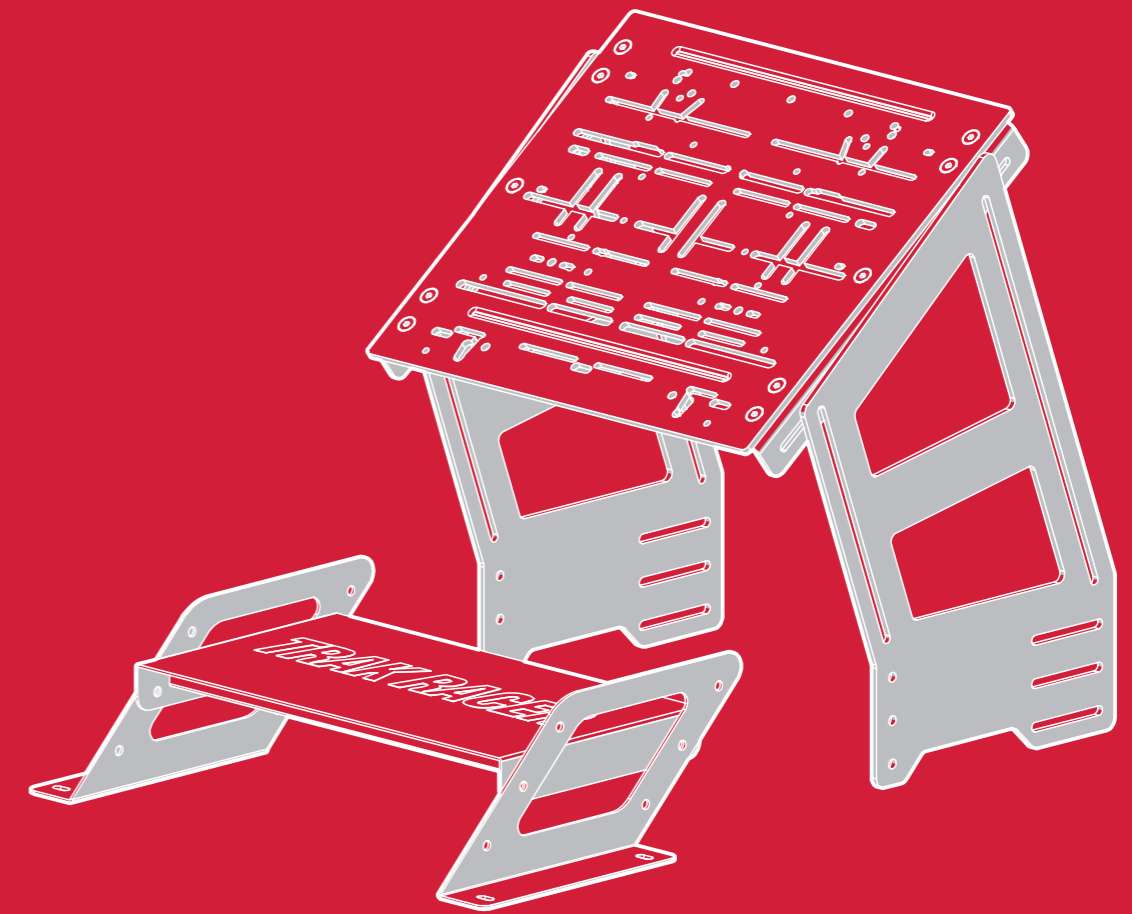

BRAKE PEDAL

Assembly Guide

TR80-HYPL2

TR80-HYPL2 PART LIST

ACCESSORIES (NOTE: Extra hardware may be included as spare parts)

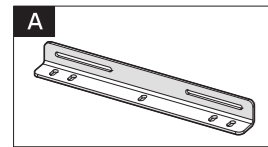

A
Pedal Plate Connector
TR80-PPC **X2**

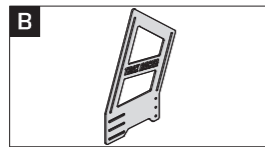

B
Pedal Plate Side Mount
TR80-PPSM-02 **X2**

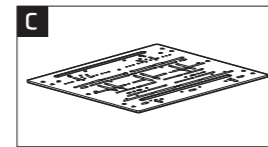

C
Pedal Plate
TR80-PP **X1**

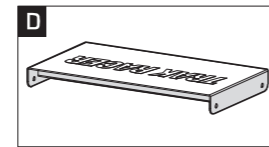

D
Hybrid Heel Plate
TR80-HHP-01 **X1**

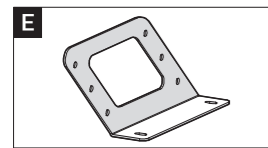

E
Hybrid Pedal Side Plate
TR80-HPSP-01 **X1**

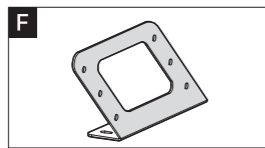

F
Hybrid Pedal Side Plate
TR80-HPSP-02 **X1**

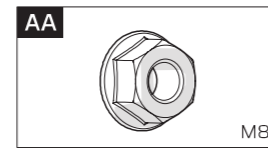

AA
Flange Nut
NF-M8 **X26**

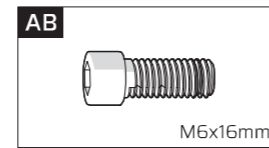

AB
Hex Screw
SH-M6-16 **X4**

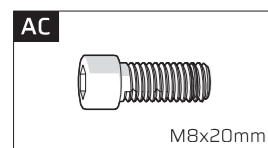

AC
Hex Screw
SH-M8-20 **X16**

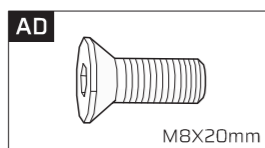

AD
Screw (Flat)
SF-M8-20 **X18**

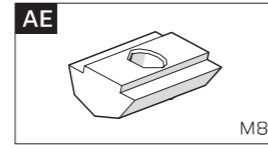

AE
Ball Bearing Nut
NS-M8 **X12**

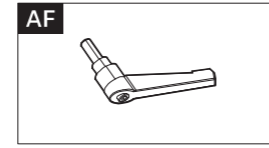

AF
Offset Hex Key
OHK-M8-25 **X4**

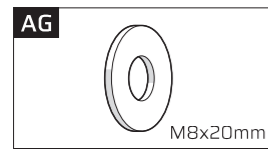

AG
Washer (Flat)
WF-M8-20 **X16**

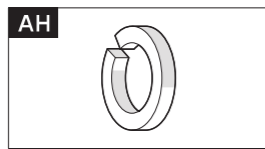

AH
Lock Washer
WL-M8 **X16**

NOTE:
Use screws and washers included in the TR1205 assembly.

ASSEMBLY INSTRUCTIONS

TR1205--TR80-HYPL2

01

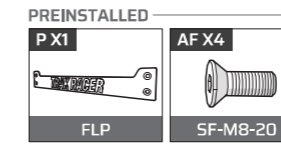

NOTE:
This step can also be changed to start after Step 16 on page 15.

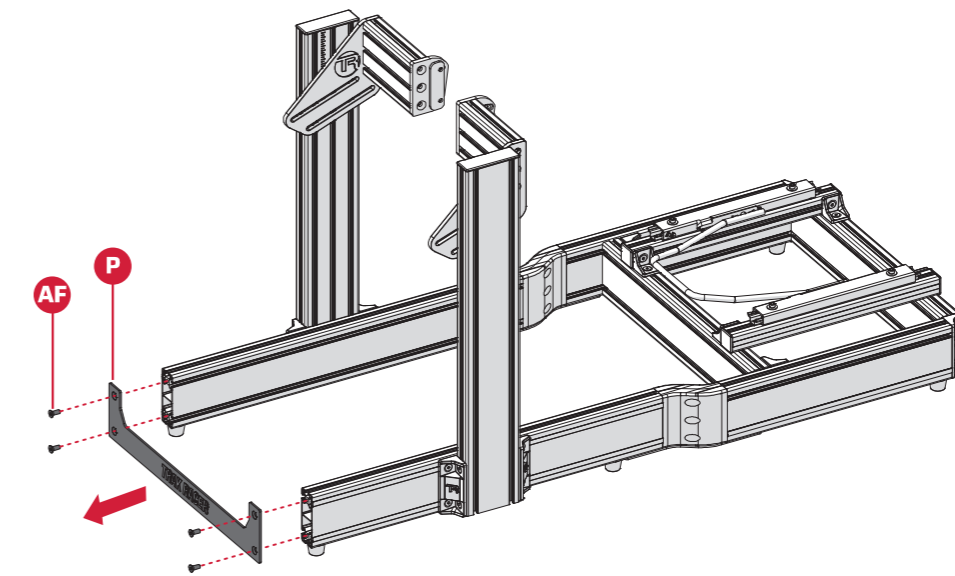

02

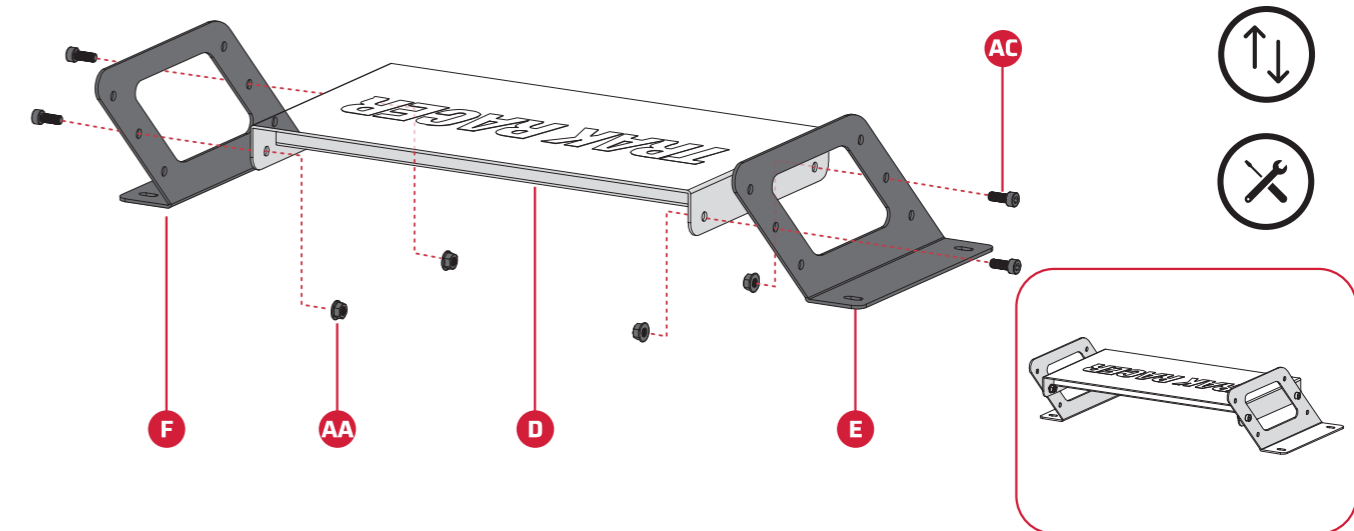
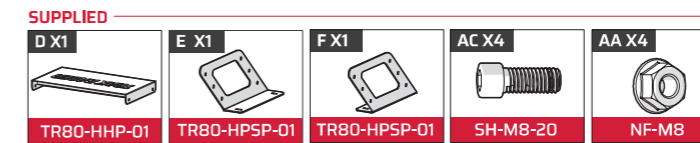

ASSEMBLY INSTRUCTIONS

TR120S--TR80-HYPL2

03

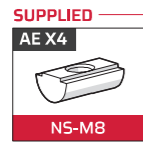

Take note of orientation of TR80-HHP-01 Brackets. They should slope towards front of the rig.

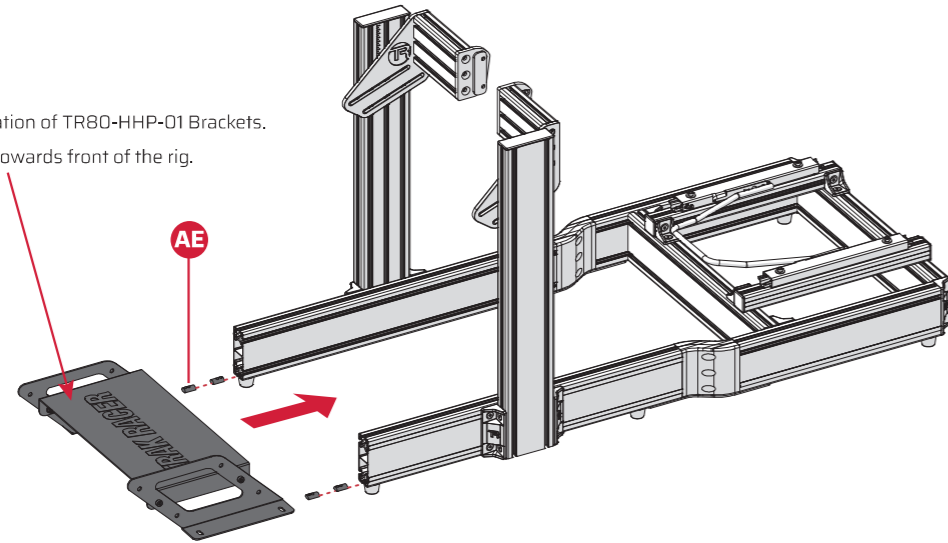

04

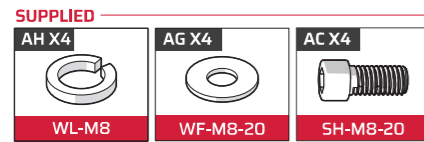

NOTE:
Push footrest as far back as possible to make room for STEP5.

NOTE:
Keep slightly loose and adjust position after seat installation.

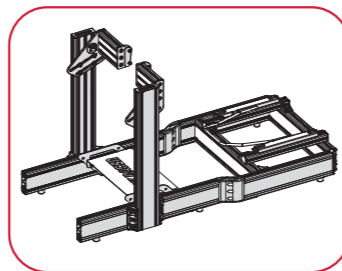
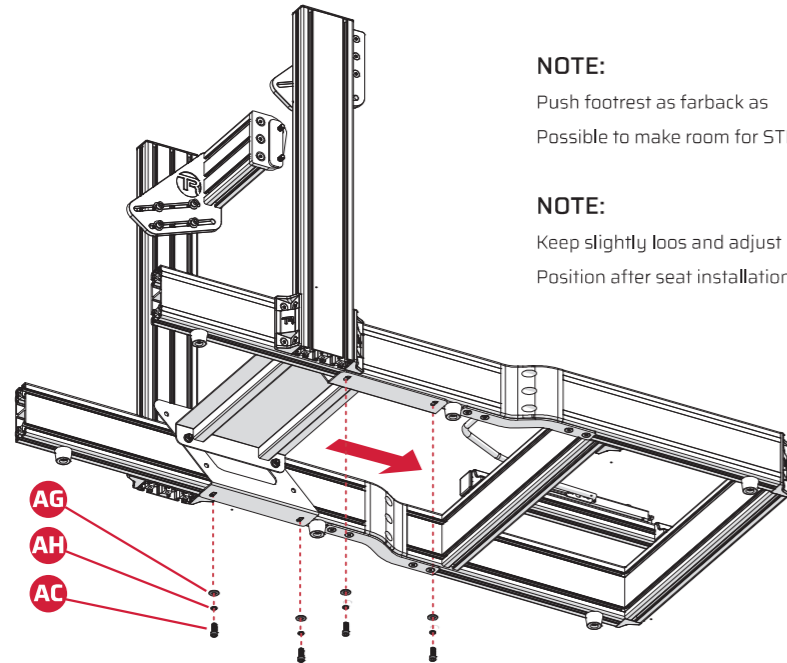

ASSEMBLY INSTRUCTIONS

TR120S--TR80-HYPL2

05

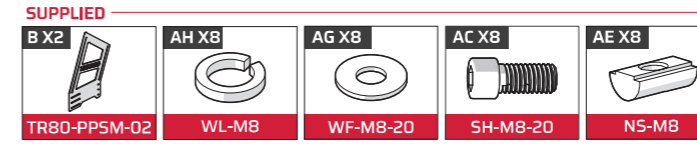

NOTE:
Keep slightly loose and adjust position after seat installation.

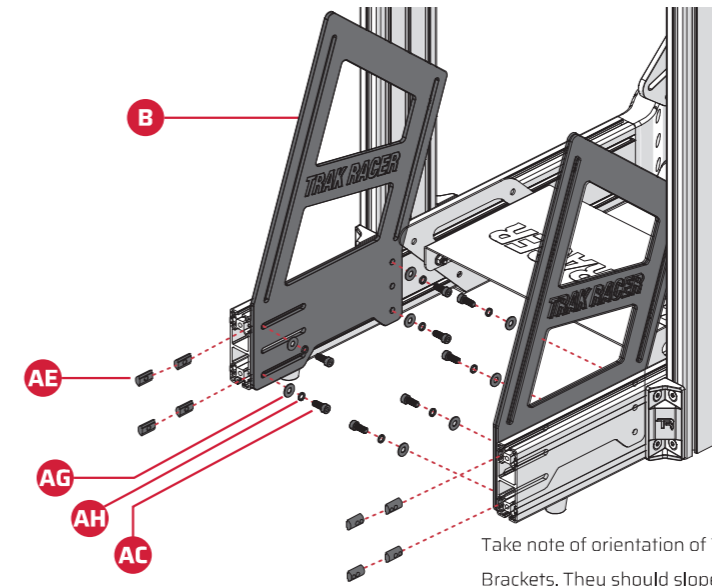

Take note of orientation of TR80-PPSM-02 Brackets. They should slope towards front of the rig.

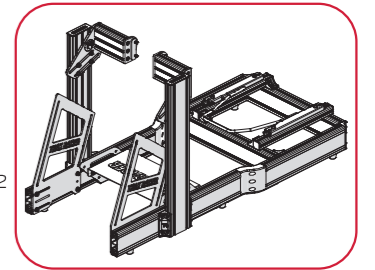

06

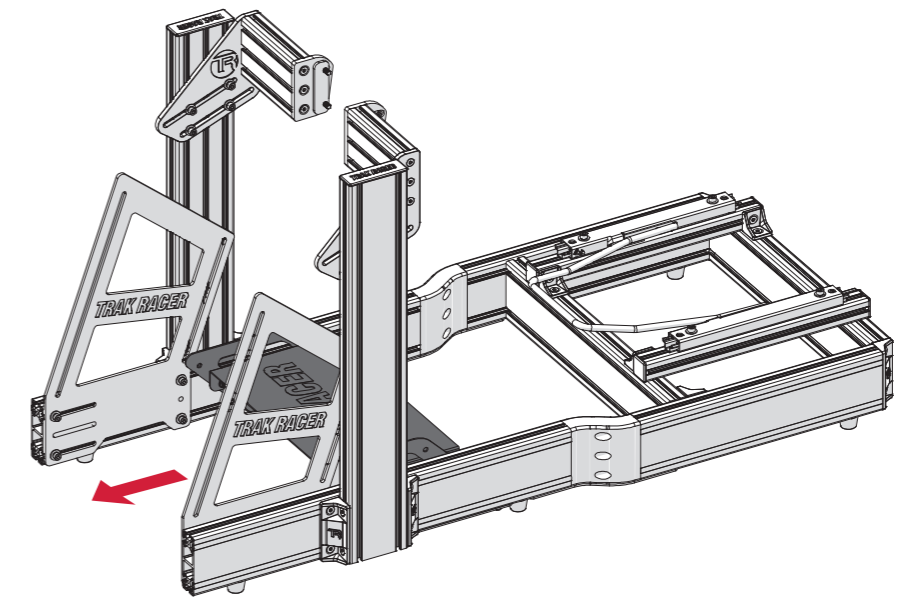

ASSEMBLY INSTRUCTIONS

TR120S--TR80-HYPL2

07

SUPPLIED

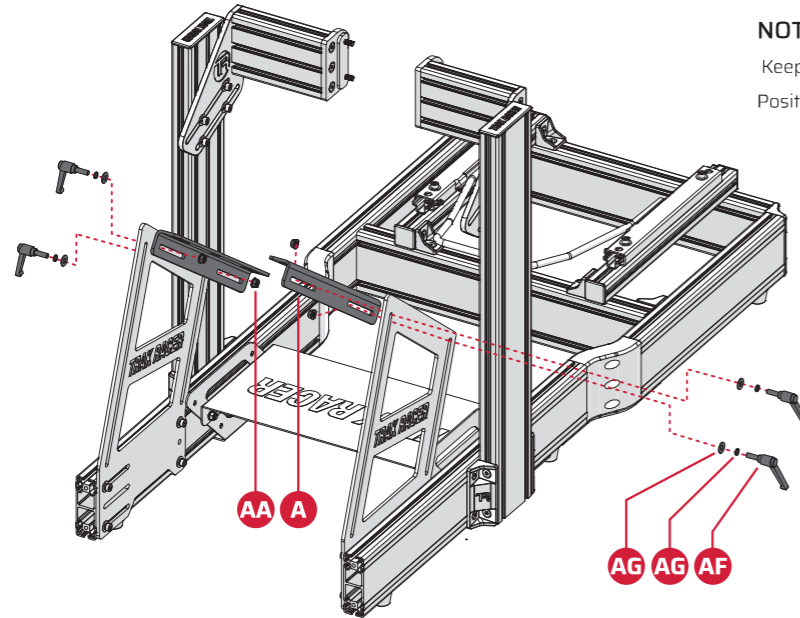
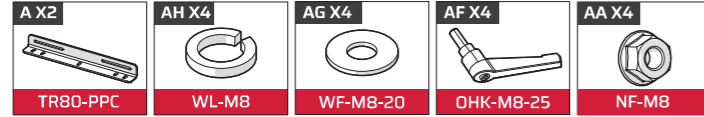

NOTE:

Keep slightly loos and adjust
Position after seat installation.

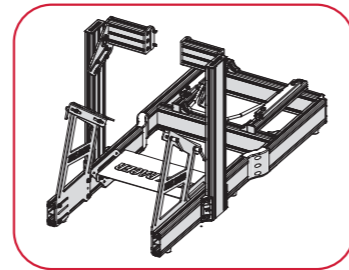

08

SUPPLIED

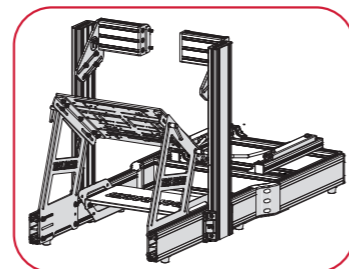
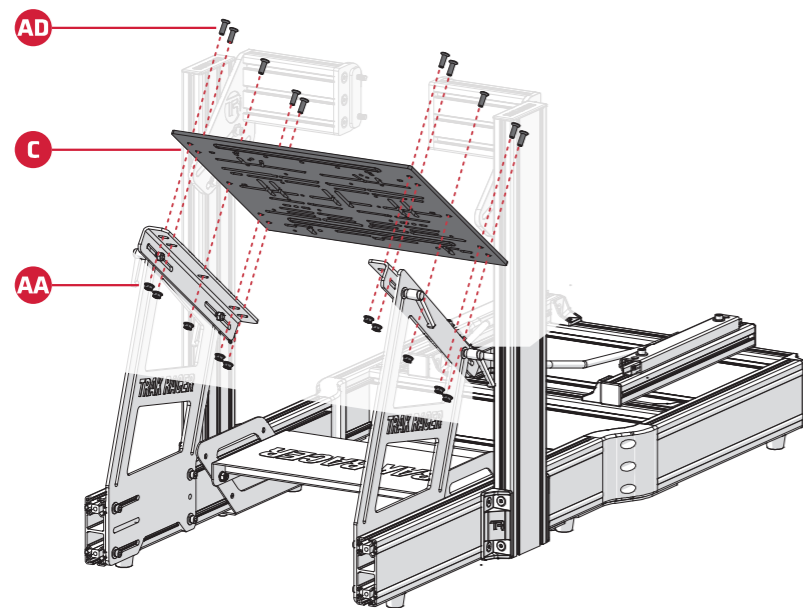

ASSEMBLY INSTRUCTIONS

TR120S--TR80-HYPL2

09

PREINSTALLED

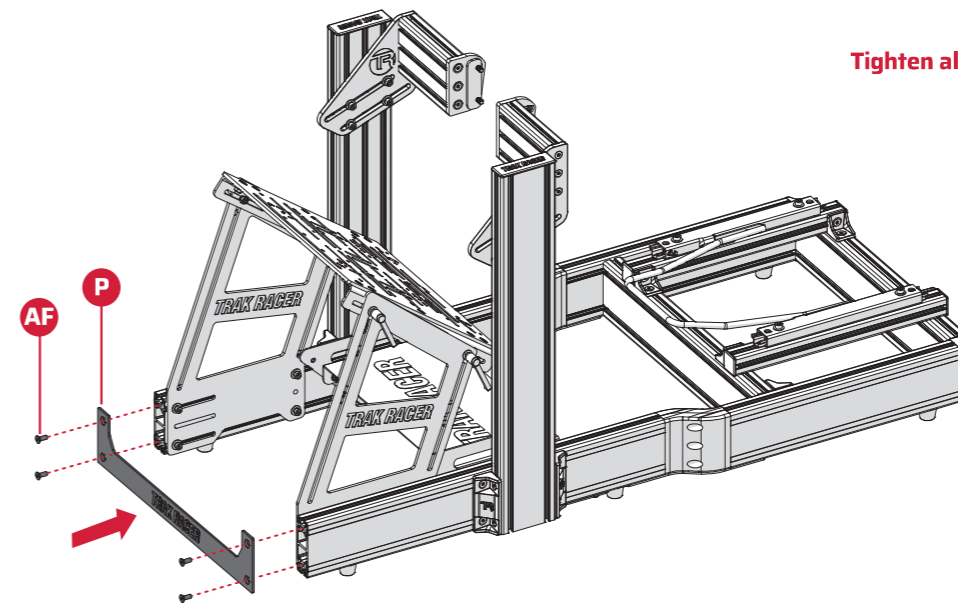
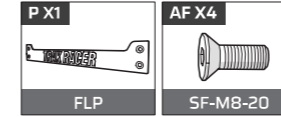

Tighten all the screws.



NOTE:

After installing the pedal, you can also proceed with the installation from step 17 on page 15.

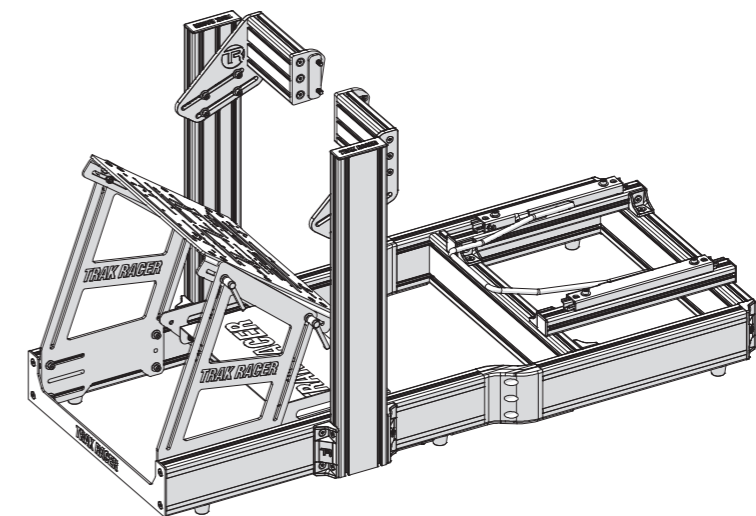

FINISHED PRODUCT